

VISITEC



**SAFETY STANDARDS
HAVE CHANGED...**

VISITEC 4602.1
100% COMPLIANT

[CLICK TO VISIT OUR WEBSITE](#)

**AUSTRALIA
NEW ZEALAND**



[CLICK TO VIEW SECTION](#)

GLOSSARY 02

AS/NZS 4602.1:2011 03

CORE STOCK 24/7 04

FUSION 05
SHIRTS / PANTS / SHORTS / SCARF / WOMEN'S

WORKWEAR 21
SHIRTS / PANTS / SHORTS / OVERALLS / VESTS

AIRWEAR POLOS 37
MEN'S & WOMEN'S

MICROFIBRE POLOS 47
MEN'S & WOMEN'S

WINTER 67
SWEATSHIRTS / FLEECEES / SHIRTS / JACKETS

WET WEATHER 81
JACKETS / VESTS / PANTS / RAINWEAR SET

NEW ZEALAND ONLY 93
JACKETS / VESTS / POLOS

SIZE GUIDE 96

INDEX 98

CONTENTS

CORE STOCK PROGRAM

Garments displaying this icon are part of our new stock guarantee program. Available when you need it 24/7. Guaranteed!

3M

Our workwear uses only genuine 3M brand reflective tape on all our taped garments, in accordance with AS/NZS 1906.4. Consistent quality control inspections ensure delivery of the genuine article.

UPF 50+

Garments displaying this feature have the highest level of UV protection: Excellent category rating for Ultra Violet Protection (UPF), the ultimate sun safety.

BREATHABLE

Garments that display this feature are breathable.

QUICK DRY

Garments displaying this feature will dry quickly after washing or heavy perspiration.

VENTING SYSTEM

Garments have a purpose built venting system to keep you cool, including our "Comfort Crotch®" (Patent Pending).

WATERPROOF

Garments that display this feature are waterproof.

ZIP IN SLEEVES

Garments displaying this feature are part of a series of component garments that can be zipped into and out of each other.

DAY

Garments displaying this feature provide the wearer with high visibility for use in daylight conditions only and comply with relevant AUS/NZ standards.

NIGHT

Garments displaying this feature provide the wearer with high visibility for use in low light and night conditions. This is achieved through the use of 3M reflective tape and complies with relevant AUS/NZ standards.

DAY/NIGHT

Garments displaying this feature provide the wearer with high visibility for use in all light conditions including day and night use, complying with relevant AUS/NZ standards.

FLUORO

Garments displaying this feature are manufactured from specially developed fluorescent materials and comply with relevant AUS/NZ standards for chromaticity.

REFLECTIVE

Garments displaying this feature are manufactured to include 3M reflective tape and comply with relevant AUS/NZ standards for reflectivity.

REFLECTIVE/FLUORO

Garments displaying this feature are manufactured from specially developed fluorescent materials plus 3M reflective tape, complying with relevant AUS/NZ standards for both class R and F.

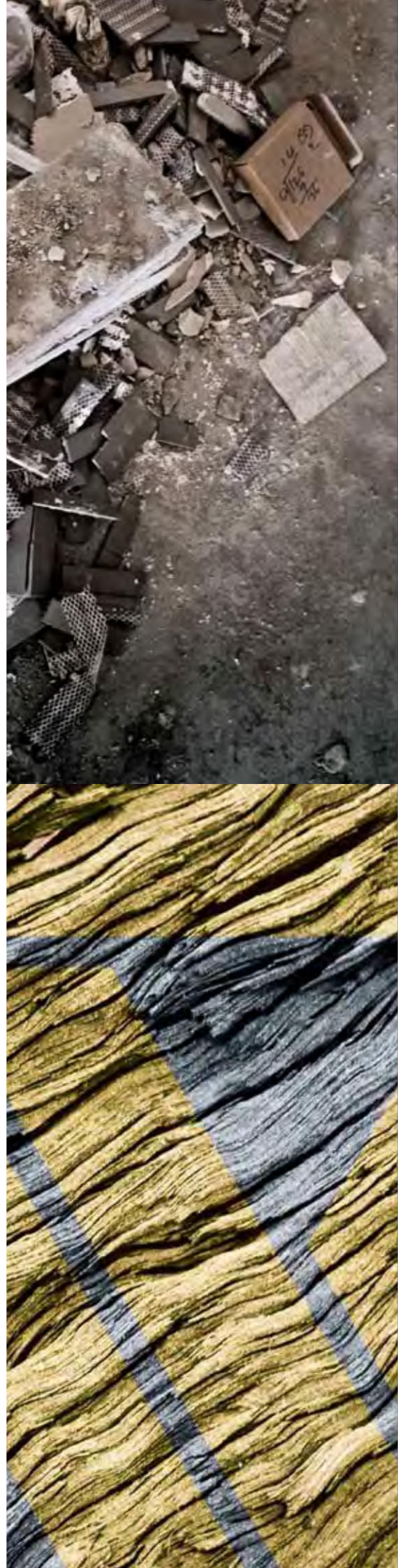

THE STANDARDS HAVE CHANGED AND SO HAVE WE...

DO YOU WEAR HIGH VIS POLO SHIRTS OR FLUORO WORK GEAR?

Then this new high visibility standard **4602.1** affects you.

MANY HIGH VISIBILITY SHIRTS WILL NO LONGER BE COMPLIANT AS OF 31/08/2012, SO HOW CAN YOU BE SURE THAT YOUR WORK GEAR IS STILL SAFE?

Check to see it has the VISITEC 4602.1 compliancy label on it. You can be sure that any garment carrying the **VISITEC 4602.1** label is 100% compliant to the new Australian standard AS/NZS 4602.1:2011 for high visibility safety garments.

SOUNDS COMPLICATED?

No, it's pretty easy really ... here's what you need to know:

The principal change from the old version of this standard is the more rigorous specification in the amount of high visibility material required on a garment for daytime visibility.

Plain English: More fluoro colour equals more safety at work.

ARE YOU PROTECTED?

With VISITEC you are. Stay safe in **VISITEC 4602.1**, as tested by accredited Australian compliancy testing authorities.

3 THINGS YOU NEED TO KNOW TO KEEP YOU SAFE...

1 IS YOUR WORKWEAR COMPLIANT TO AS/NZS 4602.1?

This standard relates to the design of the garment and specifically the amount of high visibility material on the front and back of your gear. Check the garment label; all VISITEC High Visibility workwear is 100% compliant to the new Australian standard AS/NZS 4602.1:2011 for high visibility safety garments.

2 IS THE FLUORO COLOUR COMPLIANT TO AS/NZS 1906.4?

This standard relates to the specific colour and material of your work gear. Check the garment label; all VISITEC High Visibility workwear carries the 1906.4 compliancy info.

3 ARE YOU SUN SAFE? DOES YOUR WORKWEAR COMPLY WITH AS/NZS 4399 STANDARD FOR SUN PROTECTIVE CLOTHING?

Check the garment label; All VISITEC High Visibility polo's carry the 4399 compliancy info with a rating of Excellent 40-50+.

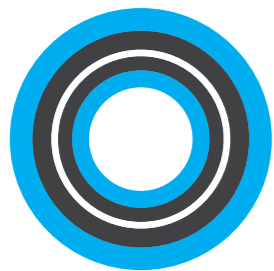
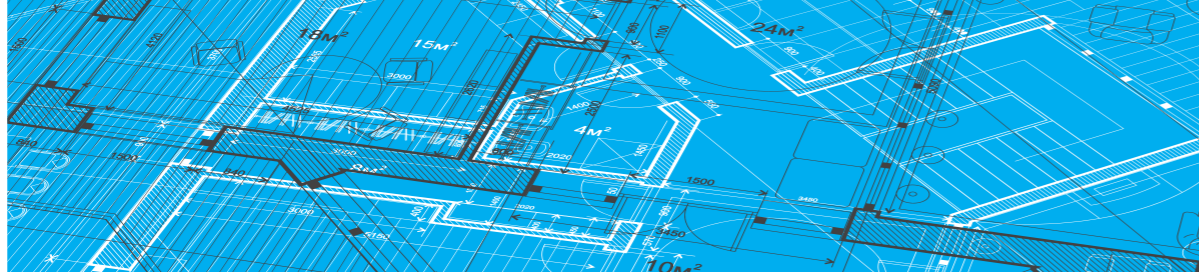

CORE STOCK PROGRAM

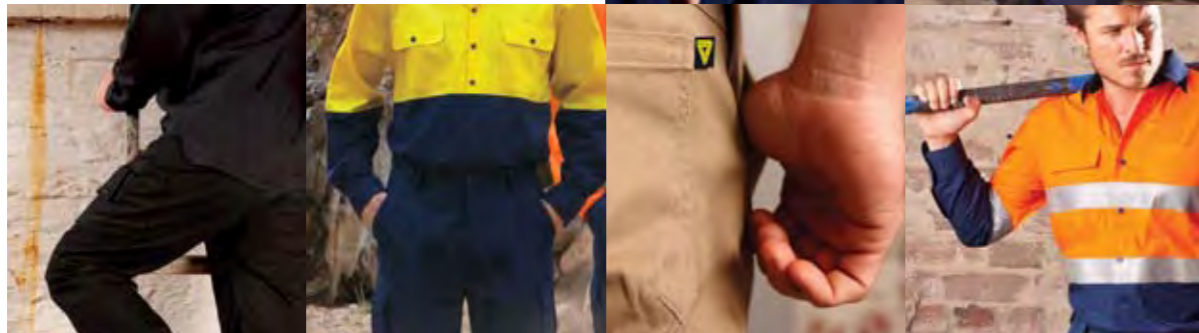
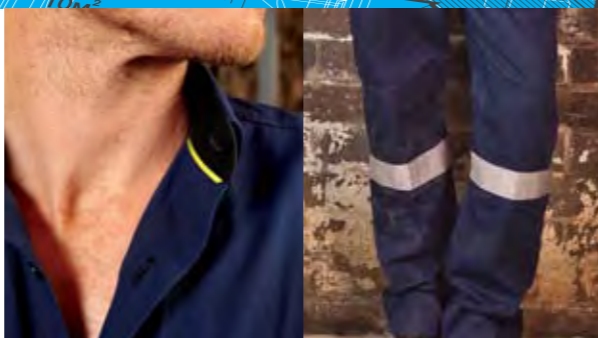

READY WHENEVER YOU NEED IT...

VISITEC understands that delivery-in-full is most important, that's why we developed **The Core Stock Program**. This is a collection of essential VISITEC gear that we guarantee will be in stock whenever you want it, 24/7.

When you see The Core Stock Program icon  in the catalogue, we guarantee these garments will be available for immediate delivery. Check that the specific colour you need is included in The Core Stock Program offer, because not all colours are included.

This is the way we do business and we guarantee it or you get \$100 credit off your next order.* Put us to the test on **The Core Stock Program**, we won't let you down.

You can find the following garments included in **The Core Stock Program**:

FUSION LIGHTWEIGHT UTILITY PANT	V8002-N	PAGE 06
FUSION UTILITY PANT	V8000-N	PAGE 07
FUSION CARGO SHORT	V9000-N	PAGE 08
FUSION CARGO PANT	V8001-N	PAGE 10
FUSION LIGHTWEIGHT SHIRT L/S	V5000-YN / V5000-ON	PAGE 14
FUSION LIGHTWEIGHT D/N HI-VIS SHIRT L/S	V5001-YN / V5001-ON	PAGE 16
COTTON DRILL WORKSHIRT L/S	WWDL-YN / WWDL-ON	PAGE 30
DAY/NIGHT VERSION HI-VIS COTTON DRILL WORKSHIRT L/S (HOOPED)	WWDRHL-YN / WWDRHL-ON	PAGE 32
ORIGINAL DRILL PANT WITH 3M REFLECTIVE TAPE	WPDR-N	PAGE 32

For more information and how to register for **The Core Stock Program** please visit our website www.visitec.com.au (Australia) www.vistec.co.nz (New Zealand). *Terms & Conditions apply.

FUSION



THE FUSION RANGE

A COMBINATION OF ELEMENTS...

The VISITEC Fusion range of cotton workwear combines a durable design with breathable comfort.

Cotton fabric is naturally absorbent, durable, breathable and biodegradable. Square weave fabric is strong, hard wearing, and most importantly, increases airflow.

VISITEC square weave cotton shirts have been tested by the CSIRO, and are 2 times more breathable than comparable light weight drill shirts.

WHAT DOES THAT MEAN FOR YOU?

These Fusion shirts will keep you cooler and more comfortable than the basic drill shirt you are wearing now.

Comfort Plus areas have been specially developed, providing absorbency to reduce chaffing at the neck and around the waist, ensuring optimum comfort and wearability.

Air vents are a standard, key feature in all Fusion garments. The **VISITEC Comfort Crotch®** (patent pending) provides an airflow to keep you cool, especially in the hot summer months, and stretch for added movement where you need it most.



◀ **FUSION LIGHTWEIGHT UTILITY PANT V8002**

- Single pleat front
- Comfort inner waistband
- Double layer knee for added durability
- Triple and double stitched seams with bar tacks
- 6 pockets incl. mobile phone and tool/ruler pocket
- Size adjustment tabs on waistband
- Complies with AS/NZS439

FABRIC 220 gram Cotton Drill
SIZES 72-107 Reg / 87-122 Stout

CODE NAVY **V8002-N**

FEATURES Venting System / UPF 50+ / CSP



◀ **FUSION UTILITY PANT V8000**

- Single pleat front
- Unique Comfort Crotch® with airflow and stretch (Patent Pending)
- Comfort inner waistband
- Double layer knee for added durability
- Triple and double stitched seams with bar tacks
- 6 pockets incl. mobile phone and tool / ruler pocket
- Size adjustment tabs on waistband
- Complies with AS/NZS4399

FABRIC 280 gram Cotton Drill
SIZES 72-107 Reg / 87-122 Stout

CODES NAVY **V8000-N**
 BLACK **V8000-B**
 KHAKI **V8000-K** (Aus Only)

FEATURES Venting System / UPF 50+ / CSP (Navy Only)



FUSION CARGO SHORT

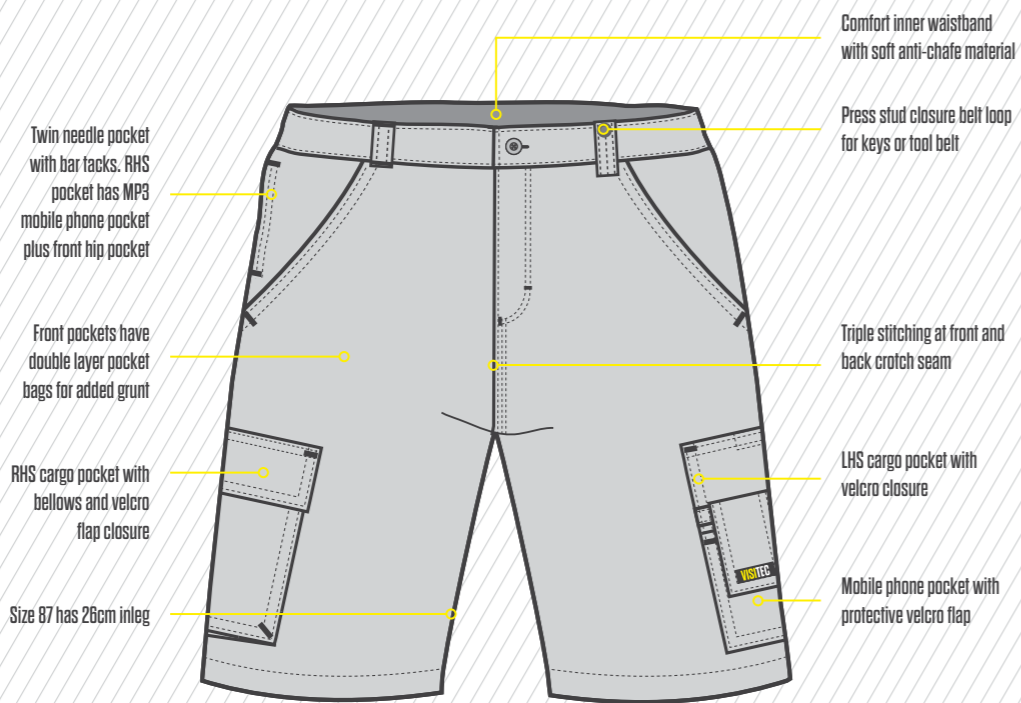

RIGHT HAND SIDE POCKET

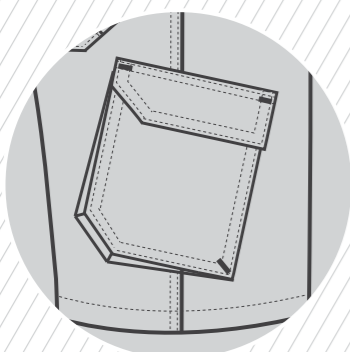

LEFT HAND SIDE POCKET

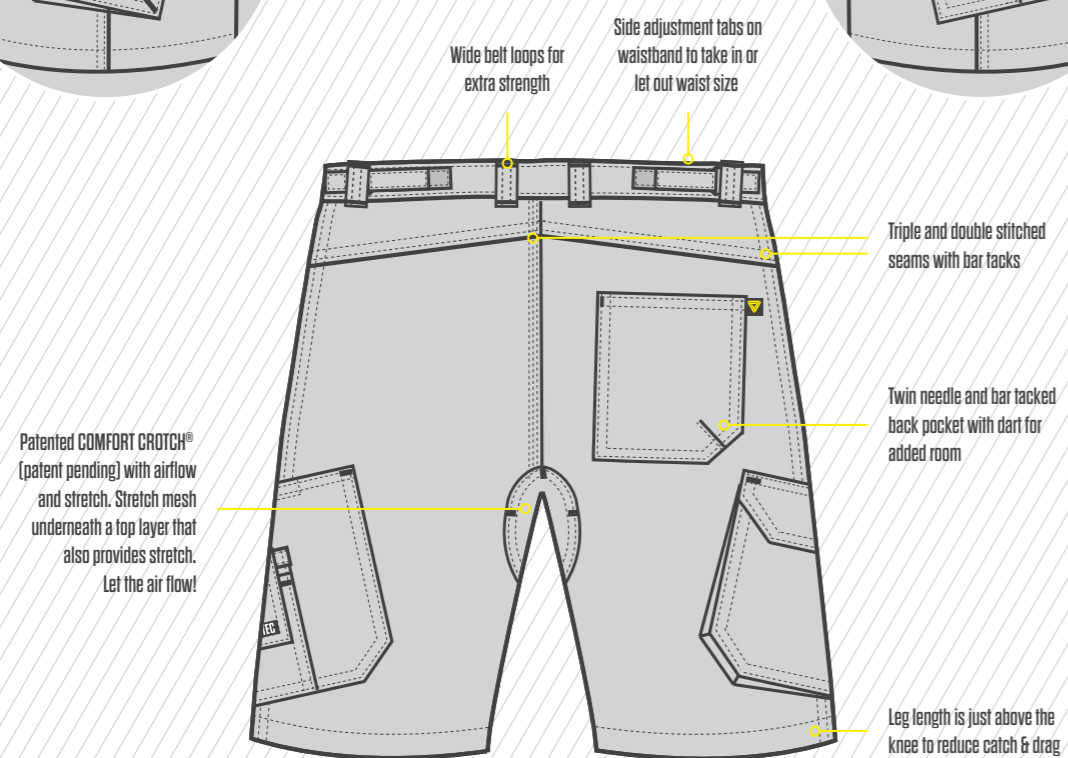
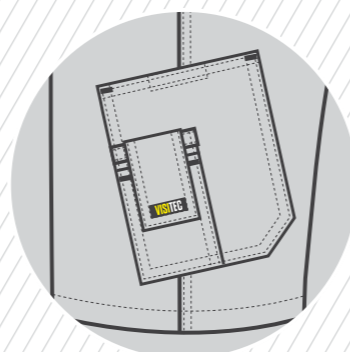

FUSION CARGO SHORT V9000

- Unique Comfort Crotch® with airflow and stretch (Patent Pending)
- Comfort inner waistband
- Triple and double stitched seams with bar tacks
- 7 pockets incl. mobile phone and multi function pockets
- Size adjustment tabs on waistband
- Complies with AS/NZS4399

FABRIC 280 gram 100% Cotton Drill
SIZES 72-117

CODES NAVY **V9000-N**
 BLACK **V9000-B**
 KHAKI **V9000-K** (Aus Only)

FEATURES Venting System / UPF 50+ / CSP (Navy Only)



SPECIAL FEATURES



FUSION CARGO PANT
KHAKI V8001-K
 Venting System / UPF 50+



FUSION CARGO PANT V8001

- Unique Comfort Crotch® with airflow and stretch (Patent Pending)
- Comfort inner waistband
- Triple and double stitched seams with bar tacks
- 7 pockets incl. mobile phone and multi function pockets
- Size adjustment tabs on waistband
- Complies with AS/NZS4399

FABRIC 280 gram 100% Cotton Drill
SIZES 72-107 Reg / 87-122 Stout

CODES NAVY **V8001-N**
 BLACK **V8001-B**
 KHAKI **V8001-K** (Aus Only)

FEATURES Venting System / UPF 50+ / CSP (Navy Only)



FUSION CARGO PANT

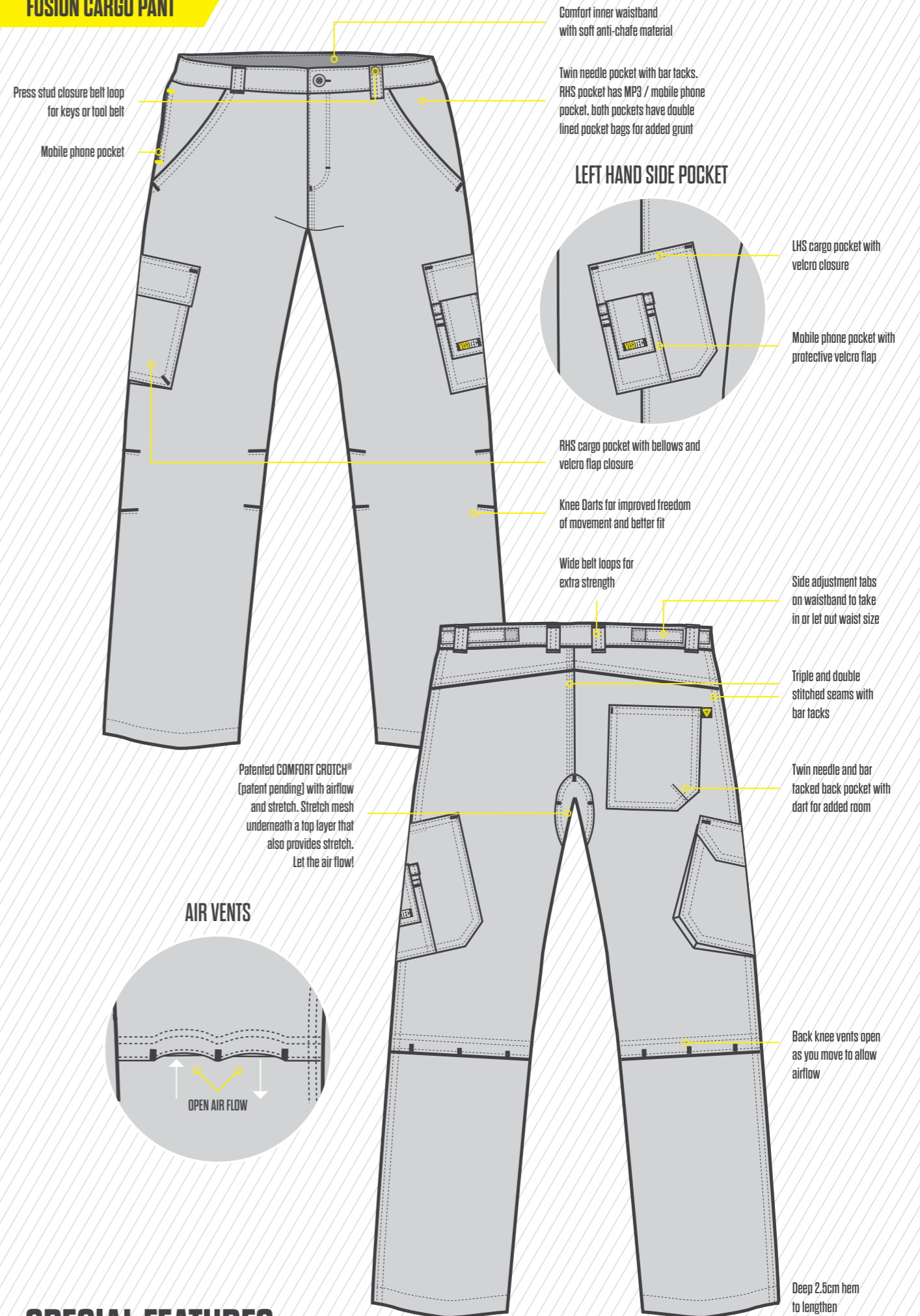

SPECIAL FEATURES



LET THE AIR
FLOW

FUSION LIGHTWEIGHT SHIRT S/S V4000

- 2 x times more breathable than equivalent drill shirts as tested by CSIRO
- Soft internal comfort collar
- Complies with AS/NZS4399
- Complies with AS/NZS4602.1 - Class D (Y/N, O/N)
- Complies with AS/NZS1906.4 - Class F (Y/N, O/N)

FABRIC 160 gram Cotton Squareweave
SIZES S-6XL

CODES YELLOW/NAVY **V4000-YN**
 ORANGE/NAVY **V4000-ON**

FEATURES Venting System / UPF 50+ / Breathable / Day / Fluoro

CODES NAVY **V4000-N**
 BLACK **V4000-B**

FEATURES Venting System / UPF 50+ / Breathable



FUSION LIGHTWEIGHT SHIRT S/S
ORANGE/NAVY V4000-ON
 Venting System / UPF 50+ / Breathable / Day / Fluoro



FUSION LIGHTWEIGHT SHIRT L/S
ORANGE/NAVY V5000-ON & YELLOW/NAVY V5000-YN
 Venting System / UPF 50+ / Breathable / Day / Fluoro / GSP



**2X MORE BREATHABLE
 THAN LIGHTWEIGHT
 COTTON DRILL**

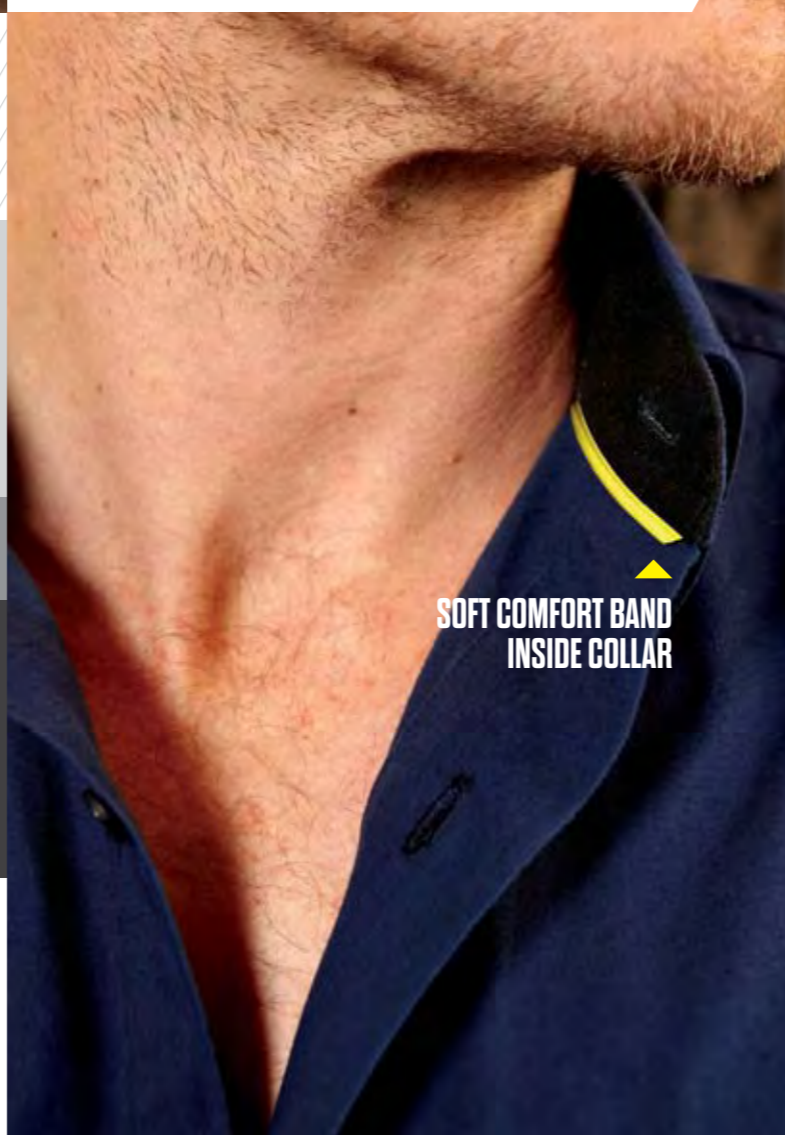

**SOFT COMFORT BAND
 INSIDE COLLAR**

FUSION LIGHTWEIGHT SHIRT L/S V5000

- 2 x times more breathable than equivalent drill shirts as tested by CSIRO
- Soft internal comfort collar
- Air flow vents standard on all Fusion range garments
- Complies with AS/NZS4399
- Complies with AS/NZS4602.1 - Class D (Y/N, O/N)
- Complies with AS/NZS1906.4 - Class F (Y/N, O/N)

FABRIC 160 gram Cotton Squareweave
SIZES S-6XL

CODES YELLOW/NAVY **V5000-YN**
 ORANGE/NAVY **V5000-ON**

FEATURES Venting System / UPF 50+ / Breathable / Day / Fluoro / GSP

CODES NAVY **V5000-N**
 BLACK **V5000-B**

FEATURES Venting System / UPF 50+ / Breathable





◀ **FUSION LIGHTWEIGHT D/N
HI-VIS SHIRT L/S V5001**

- 2 x times more breathable than equivalent drill shirts as tested by CSIRO
- Soft internal comfort collar
- Air flow vents standard on all Fusion range garments
- Genuine 50mm, 3M reflective tape
- Complies with AS/NZS4399
- Complies with AS/NZS4602.1 - Class D (Y/N, D/N)
- Complies with AS/NZS1906.4 - Class F (Y/N, D/N)

FABRIC 160 gram Cotton Squareweave
SIZES S-6XL

CODES YELLOW/NAVY **V5001-YN**
ORANGE/NAVY **V5001-ON**

FEATURES Venting System / UPF 50+ / Breathable / Day & Night / Reflective & Fluoro / 3M Tape / CSP



▲
**AIR VENTS TO
KEEP YOU COOL**

BACK OF SHIRT VIEW



◀ **VISITEC COOL SCARF VCS**

- Squareweave fabric containing water crystals
- Just soak in water and wait for crystals to expand
- Once crystals start expanding, place around the neck to create immediate cooling effect
- Helps in the prevention of heat stress

FABRIC Cotton Squareweave
SIZE One Size

CODE NAVY **VCS**

NEW



3M TAPE CONFIGURATION
SAME ON FRONT AND BACK

WOMEN'S FUSION D/N HI-VIS SHIRT L/S V5002

- Fabric is 2 x times more breathable than equivalent drill shirts as tested by CSIRO
- Soft internal comfort collar
- Bias cut side panel for freedom of movement
- Air flow vents standard on all Fusion range garments
- Genuine 3M reflective tape
- Complies with AS/NZS4399
- Complies with AS/NZS4602.1 - Class D/N
- Complies with AS/NZS1906.4 - Class R/F

FABRIC 160 gram Cotton Squareweave
SIZES 8-22

CODES YELLOW/NAVY **V5002-YN** (Arriving May 2012)
ORANGE/NAVY **V5002-ON** (Arriving May 2012)

FEATURES Venting System / UPF 50+ / Breathable / Day & Night / Reflective & Fluoro



WOMEN'S FUSION PANT V8003

- Stretch panels on waistband for comfort
- Comfort fabric on inner waistband
- Air flow vents standard on all Fusion range garments
- Triple and double stitched seams with bar tacks
- 6 pockets incl. mobile phone and multi function pockets
- Double layer comfort knee
- Ergonomic shaped side seam for fit and comfort
- Complies with AS/NZS4399

FABRIC 280 gram Cotton Drill
SIZES 8-22

CODE NAVY **V8003-N** (Arriving May 2012)

FEATURES Venting System / UPF 50+



ELASTIC PANEL
FOR COMFORT

DOUBLE LAYER
COMFORT KNEE



WOMEN'S RANGE



WORKWEAR



THE WORKWEAR RANGE

VISITEC industrial strength workwear is specifically designed for your working environment by bringing together function and technology in each design.

Our durable workwear is manufactured to the highest quality and safety standards, featuring modern design and superior comfort.

Workwear made from cotton drill and cotton square weave fabric are preshrunk to minimise shrinkage during laundering. A rigorous testing process has ensured each garment meets the highest standard of quality, and boasts stability, UV protection, abrasion resistance, colour fastness and durability.

Cotton is a naturally comfortable and hard wearing fabric, making it the perfect choice for workwear that has to withstand the elements in a tough environment.

Standard features of VISITEC workwear include:

- Twin or triple stitched seams
- Bar-tacked stress points for added strength
- Mesh venting for breathability
- High quality studs, buttons and zips for lasting function and durability
- Superior materials including 3M reflective tape and fabric from specialised mills

NEW

**INTRODUCING OUR NEW
GREAT VALUE DRILL PANT...
TOUGH JUST GOT
TOUGHER**

TITAN DRILL PANT V8005

- Washed and pre shrunk for comfort
- Reinforced binding on pocket edges for durability
- 9 multi function pockets including coin, pen, tools and cargo
- Flat front relaxed styling
- Rubber button at waist
- Double layer internal pocket bags for durability
- Crotch vents for airflow
- Double layer back crotch for strength and durability
- All stress points bar tacked
- Complies with AS/NZS 4399
- Natural Fibre Anti Static Electricity Control AS/NZS 1020: 1995

FABRIC 310 gram Cotton drill
SIZES 77-132 Reg / 87-132 Stout

CODES NAVY **V8005-N** (Arriving May 2012)
 BLACK **V8005-B** (Arriving May 2012)

FEATURES Venting System / UPF 50+



NEW

**REINFORCED POCKET
EDGES**



**ANTI-STATIC
AS/NZS 1020:1995**



◀ ENDURAMAX® PANT EPDW

- Uniquely tough Enduramax® fabric protects knees and stress areas
- Concealed flip out nail bag
- Double cargo pockets with phone, pen and multi function areas
- Discrete crotch vents assist air flow
- Triple and double stitched seams with bar tacks
- Double layer reinforced back seat and crotch area
- Complies with AS/NZS4399

FABRIC 345 gram Cotton "Duckweave" Canvas
SIZES 77-107 Reg / 87-117 Stout

CODES NAVY **EPDW-N**
 BLACK **EPDW-B**
 KHAKI **EPDW-K**

FEATURES Venting System / UPF 50+



▶ ENDURAMAX® SHORT ESDW

- Uniquely tough Enduramax® fabric protects stress areas
- Concealed flip out nail bag
- Double cargo pockets with phone, pen and multi function areas
- Discrete crotch vents assist air flow
- Triple and double stitched seams with bar tacks
- Double layer reinforced back seat and crotch area
- Complies with AS/NZS4399

FABRIC 345 gram Cotton "Duckweave" Canvas
SIZES 77-112

CODES NAVY **ESDW-N**
 BLACK **ESDW-B**
 KHAKI **ESDW-K**

FEATURES Venting System / UPF 50+

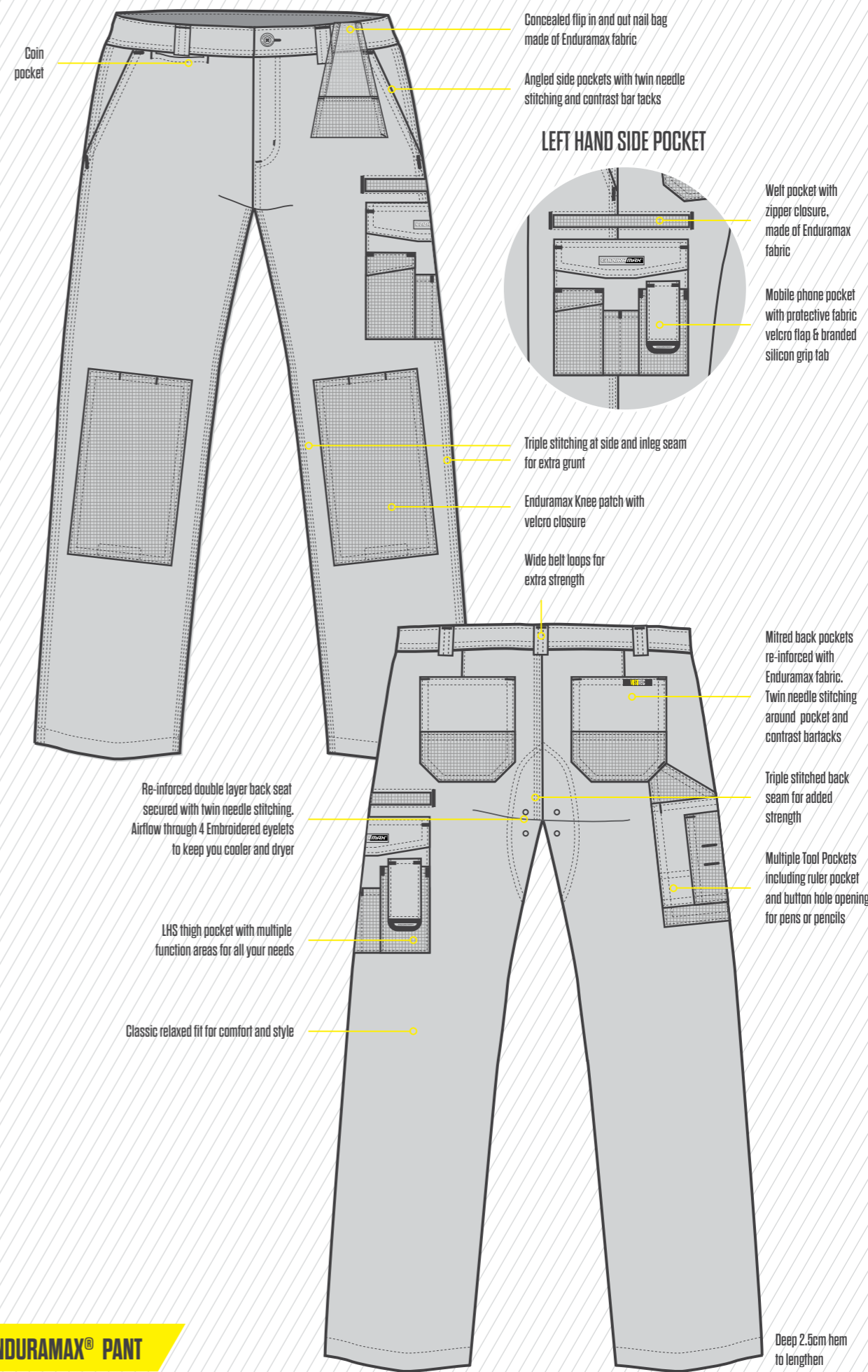

ENDURAMAX® PANT

SPECIAL FEATURES

All in 1 waistband with twin needle stitching for extra grunt

Front pockets have double layer pocket bags for added grunt with mesh panel to release water

RHS pocket with velcro closure for phone or MP3 player

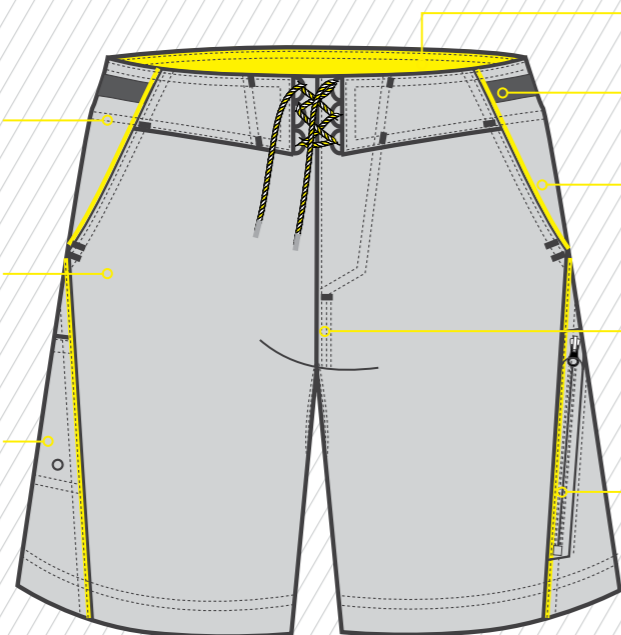

Contrast inner waistband

Velcro side adjustment tabs on waistband to take in or let out waist size

Wide angled pocket with double bartack reinforcement

Triple stitching at front and back crotch seam

LHS security pocket with inverted zipper and fabric zipper hood to stop surface scratches in the work place

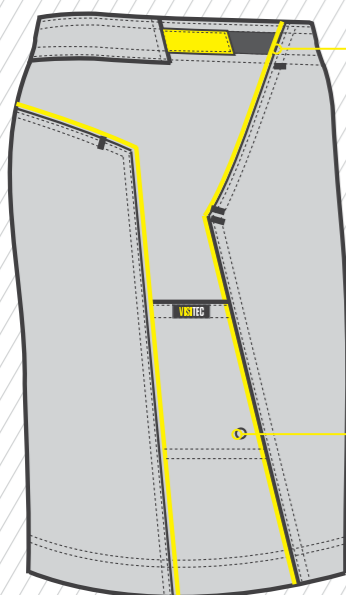

Visitec Yellow piping and double bar tacks

We've covered the metal zip puller so you dont scratch your car or your job

Laser cut eyelet for water release

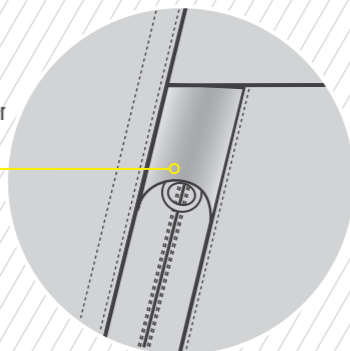

Visitec wax comb

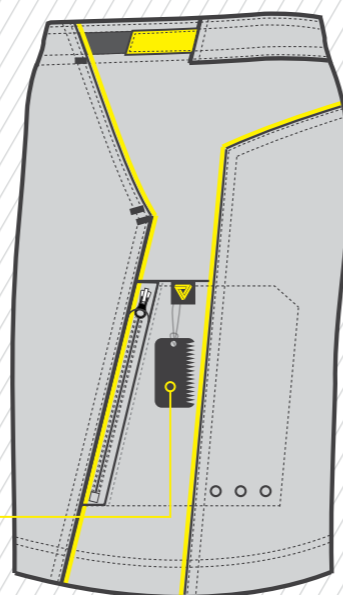

Back waistband has internal elastic for size adjustment and comfort

Back Hip pocket with mesh pocket lining and velcro closure

STRETCH CROTCH

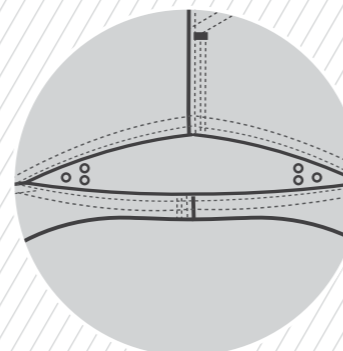

Silver reflective print across back yoke

Laser cut eyelets are far superior to metal eyelets. No scratching or rusting

Uniquely designed stretch crotch with vents for added airflow and stretch for comfort and freedom

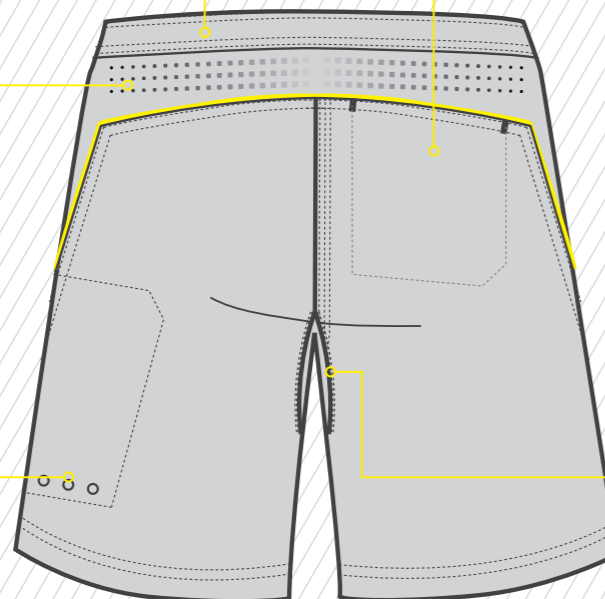

Leg length is just above the knee to reduce catch & drag

WORK BOARDIE V9001

- Built tough for Summer work and surf
- Light weight and quick dry
- Airflow stretch crotch with vents
- 5 multi function pockets incl zip security and phone pockets
- Triple and double stitched seams with bar tacks
- Reflective print on back yoke
- Wax comb inside zip pocket
- Size adjustment tabs with flexi waist
- Complies with AS/NZS4399

FABRIC 180 gram Polyester Microfibre

SIZES 77-107

CODES NAVY **V9001-N**

BLACK **V9001-B**

FEATURES Venting System / UPF 50+ / Quick Dry

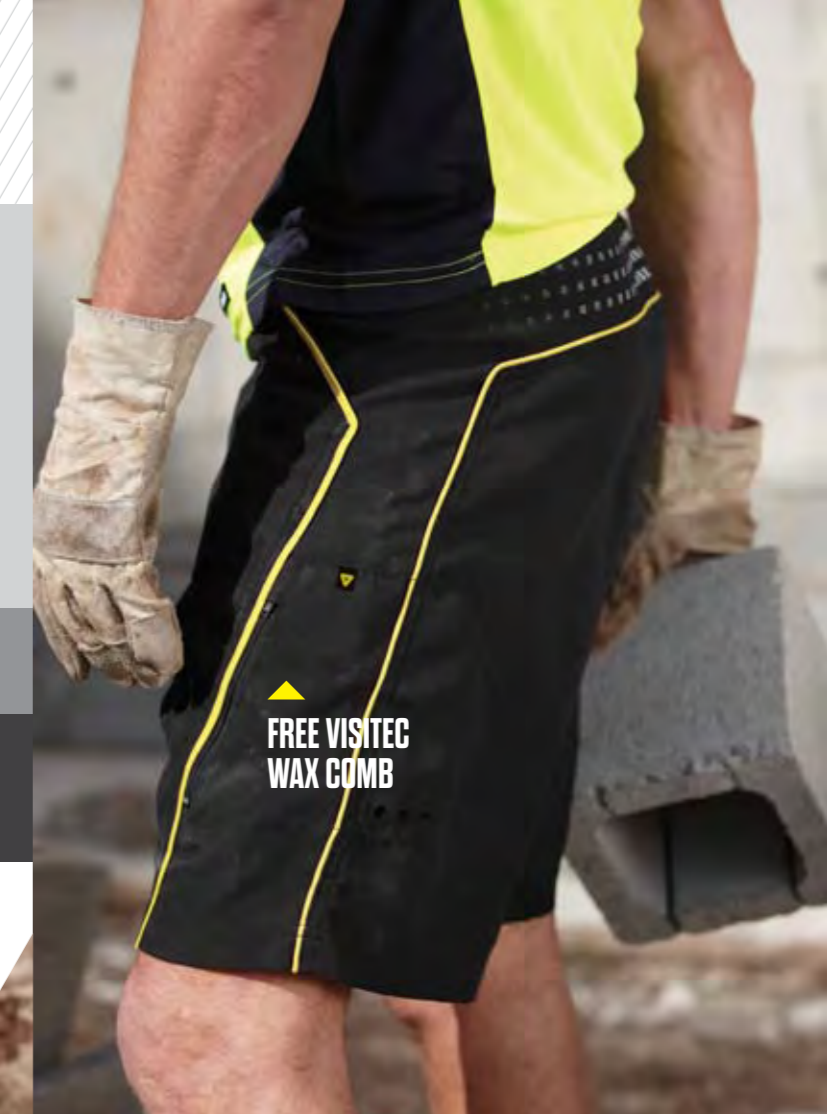

FREE VISITEC WAX COMB





◀ COTTON CARGO PANT WDCP

- Pre-softened and preshrunk
- 8 pocket cargo including multifunctional leg pockets
- Flat front relaxed fit styling
- Adjustable side tabs and belt loops
- All stress points bar-tacked for added strength
- Complies with AS/NZS4399

FABRIC 310 gram Cotton Drill
SIZES 72-132 Reg (Navy) / 87-132 Stout (Navy) / 77-117 Reg

CODES NAVY **WDCP-N**
 KHAKI **WDCP-K**
 BOTTLE **WDCP-B** (While Stocks Last)
 BLACK **WDCP-BK** (NZ Only)

FEATURE UPF 50+



◀ COTTON CARGO SHORT WDCS

- Pre-softened and preshrunk
- 8 pocket cargo including multifunctional leg pockets
- Flat front relaxed fit styling
- Adjustable side tabs and belt loops
- All stress points bar-tacked for added strength
- Complies with AS/NZS4399

FABRIC 310 gram Cotton Drill
SIZES 77-132 (Navy) / 77-117

CODES NAVY **WDCS-N**
 KHAKI **WDCS-K**
 BOTTLE **WDCS-B** (While Stocks Last)
 BLACK **WDCS-BK** (NZ Only)

FEATURE UPF 50+



COTTON DRILL WORKSHIRT S/S BOTTLE WWDS-B UPF 50+



◀ COTTON DRILL WORKSHIRT S/S WWDS

- Pre-softened & preshrunk
- Button through front with double chest button patch pockets
- Pen partition on left pocket
- Complies with AS/NZS4399
- Complies with AS/NZS4602.1 - Class D (Y/N, O/N)
- Complies with AS/NZS1906.4 - Class F (Y/N, O/N)

FABRIC 190 gram Cotton Drill
SIZES S-6XL

CODES YELLOW/NAVY **WWDS-YN**
 ORANGE/NAVY **WWDS-ON**

FEATURES UPF 50+ / Day / Fluoro

CODES NAVY **WWDS-N**
 BOTTLE **WWDS-B** (While Stocks Last)
 BLACK **WWDS-BK** (NZ Only)

FEATURES UPF 50+



NAVY PANEL ON FRONT AND BACK 29

NAVY PANEL ON FRONT AND BACK



► COTTON DRILL UTILITY PANT **WPD**

- Pre-softened and preshrunk
- Adjustable side tabs and belt loops
- Single pleat front styling
- All stress points bar-tacked for added strength
- Mobile phone pocket and ruler pocket on leg
- Complies with AS/NZS4399

FABRIC 310 gram Cotton Drill
SIZES 77-107 Reg / 92-122 Stout

CODES NAVY **WPD-N**
 BOTTLE **WPD-B** (While Stocks Last)
 KHAKI **WPD-K**

FEATURE UPF 50+



COTTON DRILL UTILITY PANT

NAVY **WPD-N**

UPF 50+



► COTTON DRILL WORKSHIRT L/S **WWDL**

- Pre-softened & preshrunk
- Button through front with double chest button patch pockets
- Pen partition on left pocket
- Complies with AS/NZS4399
- Complies with AS/NZS4602.1 - Class D (Y/N, O/N, S/O)
- Complies with AS/NZS1906.4 - Class F (Y/N, O/N, S/O)

FABRIC 190 gram Cotton Drill
SIZES S-6XL

CODES YELLOW/NAVY **WWDL-YN**
 ORANGE/NAVY **WWDL-ON**
 SAFETY ORANGE **WWDL-SO** (While Stocks Last)

FEATURES UPF 50+ / Day / Fluoro / CSP (Excluding Safety Orange)

CODES NAVY **WWDL-N**
 BOTTLE **WWDL-B** (While Stocks Last)
 BLACK **WWDL-BK** (NZ Only)

FEATURES UPF 50+



COTTON DRILL WORKSHIRT L/S

BOTTLE **WWDL-B**

UPF 50+



3M TAPE CONFIGURATION
SAME ON FRONT AND BACK



DAY/NIGHT HI-VIS COTTON DRILL
WORKSHIRT L/S (HOOPED) **WWRHL**

- Pre-softened & preshrunk
- Button through styling with double button patch chest pockets
- Contrasting front split, back split and half sleeves in two tone versions
- Genuine 50mm, 3M reflective tape
- Complies with AS/NZS 4399
- Complies with AS/NZS4602.1 - Class D/N
- Complies with AS/NZS1906.4 - Class R/F

FABRIC 190 gram Cotton Drill
SIZES S-6XL

CODES YELLOW/NAVY **WWRHL-YN**
ORANGE/NAVY **WWRHL-ON**

FEATURES UPF 50+ / Day & Night / Reflective & Fluoro / 3M Tape / CSP



3M TAPE CONFIGURATION
SAME ON FRONT AND BACK



COTTON DRILL COMBINATION
TAPED OVERALLS **WOCR**

- Pre-softened and preshrunk
- Two chest pockets
- Genuine 50mm, 3M reflective tape
- Slide-through side pockets
- All seams safety stitched and bar-tacked for added strength
- Complies with AS/NZS 4399
- Complies with AS/NZS4602.1 - Class D/N (Safety Orange), Class N (Navy)
- Complies with AS/NZS1906.4 - Class R/F (Safety Orange), Class R (Navy)

FABRIC 310 gram Cotton Drill
SIZES 77-107 Reg / 92-122 Stout

CODES SAFETY ORANGE **WOCR-SO** (AUS Only)
FEATURES UPF 50+ / Day & Night / Reflective & Fluoro / 3M Tape
CODES NAVY **WOCR-N** (AUS Only)
FEATURES UPF 50+ / Night / Reflective / 3M Tape



COTTON DRILL COMBINATION
OVERALLS **WOC**

- Pre-softened and preshrunk
- Two chest pockets
- Slide-through side pockets
- All seams safety stitched and bar tacked for added strength
- Complies with AS/NZS 4399
- Complies with AS/NZS4602.1 - Class D (Safety Orange)
- Complies with AS/NZS1906.4 - Class F (Safety Orange)

FABRIC 310 gram Cotton Drill
SIZES 77-107 Reg / 92-122 Stout

CODES SAFETY ORANGE **WOC-SO** (AUS Only)
FEATURES UPF 50+ / Day / Fluoro
CODES NAVY **WOC-N** (AUS Only)
FEATURES UPF 50+



ORIGINAL DRILL PANT WITH 3M
REFLECTIVE TAPE **WPDR**

- Preshrunk and pre softened fabric
- Size adjustment tabs on waistband
- Mobile phone and ruler pockets
- Genuine 50mm, 3M reflective tape
- Complies with AS/NZS 4399
- Complies with AS/NZS4602.1 - Class N
- Complies with AS/NZS1906.4 - Class R

FABRIC 310 gram Cotton Drill
SIZES 77-107 Reg / 87-122 Stout

CODE NAVY **WPDR-N**
FEATURES UPF 50+ / Night / Reflective / 3M Tape / CSP



3M TAPE CONFIGURATION
SAME ON FRONT AND BACK



▶ **VELCRO 'BUDGET' VEST
(DAY USE) VBVD**

- Standard style of safety vest with Velcro front closure
- Complies with AS/NZS4602.1 - Class D
- Complies with AS/NZS1906.4 - Class F

SIZES M-4XL

CODES FLUORO YELLOW **VBVD-Y**
FLUORO ORANGE **VBVD-O**

FEATURES Day / Fluoro

▶ **VELCRO 'BUDGET' VEST
(DAY/NIGHT USE) VBVN**

- Standard style of safety vest with Velcro front closure
- Genuine 50mm, 3M reflective tape
- Complies with AS/NZS4602.1 - Class D/N
- Complies with AS/NZS1906.4 - Class R/F

SIZES M-4XL

CODES FLUORO YELLOW **VBVN-Y**
FLUORO ORANGE **VBVN-O**

FEATURES Day & Night / Reflective & Fluoro / 3M Tape

ELASTIC WAIST VEST (DAY/NIGHT USE)

FLUORO ORANGE VVEN-O

Day & Night / Reflective & Fluoro / 3M Tape



▶ **ELASTIC WAIST VEST (DAY/NIGHT USE) VVEN**

- Elastic waist to ensure correct wearing
- Genuine 50mm, 3M reflective tape
- Combats entanglement and visibility problems which arise from incorrect wearing of open front vests
- Complies with AS/NZS4602.1 - Class D/N
- Complies with AS/NZS1906.4 - Class R/F

SIZES M-4XL

CODES FLUORO YELLOW **VVEN-Y**
FLUORO ORANGE **VVEN-O**

FEATURES Day & Night / Reflective & Fluoro / 3M Tape



ELASTIC WAIST VEST (DAY USE)

FLUORO YELLOW VVED-Y

Day / Fluoro



▶ **ELASTIC WAIST VEST (DAY USE) VVED**

- Elastic waist to ensure correct wearing
- Combats entanglement and visibility problems which arise from incorrect wearing of open front vests
- Complies with AS/NZS4602.1 - Class D
- Complies with AS/NZS1906.4 - Class F

SIZES M-4XL

CODES FLUORO YELLOW **VVED-Y**
FLUORO ORANGE **VVED-O**

FEATURES Day / Fluoro



AIRWEAR



THE AIRWEAR RANGE

**6 X MORE BREATHABLE THAN
LIGHTWEIGHT COTTON.**

WORK HARDER, BREATHE EASIER...

VISITEC AIRWEAR® is a patented breakthrough in breathable fabric technology, which increases airflow around your body, creating it's own venting system.

VISITEC AIRWEAR® has been independently tested by the CSIRO, which has confirmed that this unique fabric is superior in air permeability and in transporting moisture away from the body in comparison to other regular workwear fabrics, including 100% cotton and regular polyester.

VISITEC AIRWEAR® reduces heat by allowing body sweat to be transported through the unique fabric structure, resulting in quicker evaporation. The fabric's lightweight structure and grid system also allows for maximum airflow between the body and garment, ensuring you'll stay cool.

SUBLIMATION PRINTING

Garments carrying the sublimation warning have been created using a printing process called sublimation printing. This process provides sharp and bright fluoro colours with a great soft hand feel. Special care needs to be taken when decorating these polos: Sublimated garments are heat sensitive and colour migration will occur if you do not follow the care instructions. If you are screen printing you **MUST** lay them flat at all times and do not fold any parts during heating or drying processes. Polo's must remain flat and separated while they cool down completely after printing or colour migration may occur. For more information please contact customer service.

NEW



MATRIX AIRWEAR® POLO SHIRT S/S VIOIO

- Sublimation print on sleeve and body
- AIRWEAR® grid structure of fabric expands and lifts moisture away from the body
- AIRWEAR® grid structure allows maximum airflow between the body and garment increasing drying time, keeping you cool
- More breathable and quick-dry in comparison to cotton fabrications
- Easy care wash & wear characteristics
- Complies with AS/NZS4399
- Complies with AS/NZS4602.1 - Class D
- Complies with AS/NZS1906.4 - Class F

FABRIC 160 gram Microfibre AIRWEAR®
SIZES S-6XL

CODES YELLOW/NAVY VIOIO-YN (Arriving April 2012)
ORANGE/NAVY VIOIO-ON (Arriving April 2012)

FEATURES UPF 50+ / Breathable / Quick Dry / Day / Fluoro



MATRIX AIRWEAR® POLO SHIRT S/S
YELLOW/NAVY VIOIO-YN
UPF 50+ / Breathable / Quick Dry / Day / Fluoro

CHARGER AIRWEAR® POLO SHIRT S/S CVPAS

- Sublimation printed sleeve and front design
- Breathable AIRWEAR® back neck yoke
- AIRWEAR® grid structure of fabric expands and lifts moisture to surface
- AIRWEAR® grid structure allows maximum airflow between the body and garment increasing drying times
- Tested by CSIRO as 6 times more breathable than comparable cotton fabrics
- Wash n wear characteristics
- Complies with AS/NZS4399
- Complies with AS/NZS4602.1 - Class D
- Complies with AS/NZS1906.4 - Class F

FABRIC 160 gram Microfibre AIRWEAR®
SIZES S-6XL

CODES YELLOW/NAVY CVPAS-YN
ORANGE/NAVY CVPAS-ON

FEATURES UPF 50+ / Breathable / Quick Dry / Day / Fluoro



CHARGER AIRWEAR® POLO SHIRT S/S

ORANGE/NAVY VIOIO-ON
UPF 50+ / Breathable / Quick Dry / Day / Fluoro





FIREWIRE AIRWEAR® POLO SHIRT S/S

YELLOW/NAVY V1009-YN

UPF 50+ / Breathable / Quick Dry / Day / Fluoro



NEW



▶ WARRIOR AIRWEAR® POLO SHIRT S/S V1004

- Unique sublimation printed body and sleeve design
- AIRWEAR® grid structure of fabric expands and lifts moisture to surface
- AIRWEAR® grid increases drying times
- Tested by CSIRO as 6 times more breathable than comparable cotton fabrics
- Wash n wear characteristics
- Complies with AS/NZS4399
- Complies with AS/NZS4602.1 - Class D
- Complies with AS/NZS1906.4 - Class F

FABRIC 160 gram Microfibre AIRWEAR®

SIZES S-6XL

CODES YELLOW/NAVY **V1004-YN**

ORANGE/NAVY **V1004-ON**

FEATURES UPF 50+ / Breathable / Quick Dry / Day / Fluoro



WARRIOR AIRWEAR® POLO SHIRT S/S

ORANGE/NAVY V1004-ON

UPF 50+ / Breathable / Quick Dry / Day / Fluoro

▶ FIREWIRE AIRWEAR® POLO SHIRT S/S V1009

- Sublimation print on sleeve and body
- AIRWEAR® grid structure of fabric expands and lifts moisture away from the body
- AIRWEAR® grid structure allows maximum airflow between the body and garment increasing drying time, keeping you cool
- More breathable and quick-dry in comparison to cotton fabrications
- Easy care wash & wear characteristics
- Complies with AS/NZS4399
- Complies with AS/NZS4602.1 - Class D
- Complies with AS/NZS1906.4 - Class F

FABRIC 160 gram Microfibre AIRWEAR®

SIZES S-6XL

CODES YELLOW/NAVY **V1009-YN** (Arriving April 2012)

ORANGE/NAVY **V1009-ON** (Arriving April 2012)

FEATURES UPF 50+ / Breathable / Quick Dry / Day / Fluoro



PRO AIRWEAR® POLO SHIRT S/S V1005

- Unique sublimation printed body and sleeve design
- AIRWEAR® grid structure of fabric expands and lifts moisture to surface
- AIRWEAR® grid increases drying times
- Tested by CSIRO as 6 times more breathable than comparable cotton fabrics
- Wash n wear characteristics
- Complies with AS/NZS4399
- Complies with AS/NZS4602.1 - Class D
- Complies with AS/NZS1906.4 - Class F

FABRIC 160 gram Microfibre AIRWEAR®

SIZES S-6XL

CODES YELLOW/NAVY **V1005-YN**

ORANGE/NAVY **V1005-ON**

FEATURES UPF 50+ / Breathable / Quick Dry / Day / Fluoro



PRO AIRWEAR® POLO SHIRT S/S

ORANGE/NAVY/WHITE V1005-ON

UPF 50+ / Breathable / Quick Dry / Day / Fluoro



SUBLIMATION PRINTING

Garments carrying the sublimation warning have been created using a printing process called sublimation printing. This process provides sharp and bright fluoro colours with a great soft hand feel. Special care needs to be taken when decorating these polos: Sublimated garments are heat sensitive and colour migration will occur if you do not follow the care instructions. If you are screen printing you MUST lay them flat at all times and do not fold any parts during heating or drying processes. Polo's must remain flat and separated while they cool down completely after printing or colour migration may occur. For more information please contact customer service.



MEN'S & WOMEN'S CLASSIC AIRWEAR® POLO SHIRT S/S V1006/V1007

- Plain colour AIRWEAR® polo shirt with white tipping
- Separate pocket enables embroidery or branding
- AIRWEAR® grid structure of fabric expands and lifts moisture to surface
- AIRWEAR® grid increases drying times
- Tested by CSIRO as 6 times more breathable than comparable cotton fabrics
- Wash n wear characteristics
- Complies with AS/NZS4399

FABRIC 160 gram Microfibre AIRWEAR®
SIZES WOMEN'S 8-16 / MEN'S S-4XL

CODES WOMEN'S NAVY **V1007-N**
 MEN'S NAVY **V1006-N**
 WOMEN'S BLACK **V1007-BK** (Available from the end of April)
 MEN'S BLACK **V1006-BK** (Available from the end of April)

FEATURES UPF 50+ / Breathable / Quick Dry



BASIC AIRWEAR® POLO SHIRT L/S

ORANGE/NAVY VPAL-ON

UPF 50+ / Breathable / Quick Dry / Day / Fluoro



MEN'S & WOMEN'S BASIC AIRWEAR® POLO SHIRT S/S VPAS

- AIRWEAR® grid structure of fabric expands and lifts moisture to surface
- AIRWEAR® grid structure allows maximum airflow between the body and garment increasing drying times
- Tested by CSIRO as 6 times more breathable than comparable cotton fabrics
- Button down left breast pocket with pen partition (men's only)
- Wash n wear characteristics
- Complies with AS/NZS4399
- Complies with AS/NZS4602.1 - Class D
- Complies with AS/NZS1906.4 - Class F

FABRIC 160 gram Microfibre AIRWEAR®
SIZES WOMEN'S 8-16 / MEN'S S-6XL

CODES YELLOW/NAVY **VPAS-YN**
 ORANGE/NAVY **VPAS-ON**

FEATURES UPF 50+ / Breathable / Quick Dry / Day / Fluoro



NAVY PANEL ON FRONT ONLY

MEN'S & WOMEN'S BASIC AIRWEAR® POLO SHIRT L/S VPAL

- AIRWEAR® grid structure of fabric expands and lifts moisture to surface
- AIRWEAR® grid structure allows maximum airflow between the body and garment increasing drying times
- Tested by CSIRO as 6 times more breathable than comparable cotton fabrics
- Button down left breast pocket with pen partition (men's only)
- Wash n wear characteristics
- Complies with AS/NZS4399
- Complies with AS/NZS4602.1 - Class D
- Complies with AS/NZS1906.4 - Class F

FABRIC 160 gram Microfibre AIRWEAR®
SIZES WOMEN'S 8-16 / MEN'S S-6XL

CODES YELLOW/NAVY **VPAL-YN**
 ORANGE/NAVY **VPAL-ON**

FEATURES UPF 50+ / Breathable / Quick Dry / Day / Fluoro



NAVY PANEL ON FRONT ONLY

MICROFIBRE



THE MICROFIBRE RANGE

MICROFIBRE VS. MICROMESH... WHAT'S THE DIFFERENCE?

Micromesh describes the structure of the fabric. Microfibre describes the yarn the fabric is woven from.

Most high visibility polo shirts in the Australasian market are made from standard polyester micromesh, resulting in a lesser quality garment. VISITEC only uses high quality microfibre, ensuring durable, micro mesh polo shirts that offer superior performance and feel.

MICROFIBRE...THE FACTS!

Microfibres are densely packed filaments, contained within a hollow fibre. The fibres result in a soft, breathable fabric, ensuring maximum comfort. The fabric is quick drying and boasts excellent wash and wear properties.

RACING STRIPE MICROFIBRE POLO SHIRT S/S
YELLOW/NAVY/GREY V1008-YNG & YELLOW/NAVY V1008-YN
 UPF 50+ / Breathable / Quick Dry / Day / Fluoro



RACING STRIPE MICROFIBRE POLO SHIRT S/S V1008

- Screen printed racing stripes on sleeve and shoulder yoke
- Genuine soft-touch Microfibre
- Navy spliced lower front panel
- Breathable and quick dry fabric
- Unique panel design with contrast silver/grey piping
- Complies with AS/NZS4399
- Complies with AS/NZS4602.1 - Class D
- Complies with AS/NZS1906.4 - Class F

FABRIC 175 gram Microfibre
SIZES S-6XL

CODES YELLOW/NAVY **V1008-YN**
 ORANGE/NAVY **V1008-ON**
 YELLOW/NAVY/GREY **V1008-YNG**
 ORANGE/NAVY/GREY **V1008-ONG**

FEATURES UPF 50+ / Breathable / Quick Dry / Day / Fluoro



RACING STRIPE MICROFIBRE POLO SHIRT L/S
ORANGE / NAVY V2003-ON & YELLOW/NAVY V2003-YN
 UPF 50+ / Breathable / Quick Dry / Day / Fluoro



RACING STRIPE MICROFIBRE POLO SHIRT L/S V2003

- Screen printed racing stripes on sleeve and shoulder yoke
- Genuine soft-touch Microfibre
- Navy spliced lower front panel
- Breathable and quick dry fabric
- Unique panel design with contrast silver/grey piping
- Complies with AS/NZS4399
- Complies with AS/NZS4602.1 - Class D
- Complies with AS/NZS1906.4 - Class F

FABRIC 175 gram Microfibre
SIZES S-6XL

CODES YELLOW/NAVY **V2003-YN**
 ORANGE/NAVY **V2003-ON**
 YELLOW/NAVY/GREY **V2003-YNG**
 ORANGE/NAVY/GREY **V2003-ONG**

FEATURES UPF 50+ / Breathable / Quick Dry / Day / Fluoro



NEW



GEO MICROFIBRE POLO SHIRT S/S
YELLOW/NAVY/GREY VIOII-YNG
 UPF 50+ / Breathable / Quick Dry / Day / Fluoro



GEO MICROFIBRE POLO SHIRT S/S VIOII

- Screen printed design on sleeves
- Genuine soft-touch Microfibre
- Navy spliced lower front panel
- Breathable and quick dry fabric
- Unique panel design with contrast silver grey piping
- Complies with AS/NZS4399
- Complies with AS/NZS4602.1 - Class D
- Complies with AS/NZS1906.4 - Class F

FABRIC 175 gram Microfibre
SIZES S-6XL

CODES YELLOW/NAVY/RED **VIOII-YNR**
 ORANGE/NAVY/WHITE **VIOII-ONW**
 YELLOW/NAVY/GREY **VIOII-YNG**

FEATURES UPF 50+ / Breathable / Quick Dry / Day / Fluoro



GEO AIRWEAR® POLO SHIRT S/S
ORANGE/NAVY/WHITE VIOII-ONW
 UPF 50+ / Breathable / Quick Dry / Day / Fluoro

NEW



**SLEEVE
 DETAIL**

NEW



RACING STRIPE MICROFIBRE SINGLET
ORANGE/NAVY V1012-ON & YELLOW/NAVY V1012-YN
UPF 50+ / Breathable / Quick Dry / Day / Fluoro



RACING STRIPE MICROFIBRE
SINGLET V1012

- Screen printed racing stripes on side panel
- Genuine soft-touch Microfibre
- Breathable and quick dry fabric
- Navy binding on armhole and neck
- Complies with AS/NZS4602.1 - Class D
- Complies with AS/NZS1906.4 - Class F

FABRIC 175 gram Microfibre
SIZES S-6XL

CODES YELLOW/NAVY V1012-YN
ORANGE/NAVY V1012-ON

FEATURES UPF 50+ / Breathable / Quick Dry / Day / Fluoro



NEW

NEW



TRIO MICROFIBRE SINGLET V1013

- Genuine soft-touch Microfibre
- Navy contrast side panels and binding
- Natural moisture removal characteristics
- Breathable and quick-dry fabric
- Easy care wash & wear characteristics
- Complies with AS/NZS4602.1 - Class D
- Complies with AS/NZS1906.4 - Class F

FABRIC 175 gram Microfibre
SIZES S-6XL

CODES YELLOW/NAVY V1013-YN
 ORANGE/NAVY V1013-ON

FEATURES UPF 50+ / Breathable / Quick Dry / Day / Fluoro



TRIO MICROFIBRE SINGLET
 ORANGE/NAVY V1013-ON & YELLOW/NAVY V1013-YN
 UPF 50+ / Breathable / Quick Dry / Day / Fluoro

VORTEX MICROFIBRE POLO SHIRT S/S

YELLOW/NAVY VVPMS-YN

UPF 50+ / Breathable / Quick Dry / Day / Fluoro



VORTEX MICROFIBRE POLO SHIRT S/S VVPMS

- Genuine soft-touch microfibre
- Contrasting sleeve stripe design and unique work panels
- Natural moisture removal characteristics
- Breathable and quick-dry
- Button down left breast pocket with pen partition
- Wash n wear characteristics
- Complies with AS/NZS4399
- Complies with AS/NZS4602.1 - Class D
- Complies with AS/NZS1906.4 - Class F

FABRIC 175 gram Microfibre
SIZES S-6XL

CODES YELLOW/NAVY VVPMS-YN
 ORANGE/NAVY VVPMS-ON

FEATURES UPF 50+ / Breathable / Quick Dry / Day / Fluoro





NAVY PANEL ON FRONT ONLY

MEN'S & WOMEN'S ENERGY POLO SHIRT S/S V1002/V1003

- Genuine soft touch microfibre
- Unique sleeve design with MP3 pocket
- Contrast spliced work front panel
- Men's and Women's fit available
- Complies with AS/NZS4399
- Complies with AS/NZS4602.1 - Class D
- Complies with AS/NZS1906.4 - Class F

FABRIC 175 gram Microfibre
SIZES WOMEN'S 8-16 / MEN'S S-6X

CODES WOMEN'S YELLOW/NAVY **V1003-YN**
 MEN'S YELLOW/NAVY **V1002-YN**
 WOMEN'S ORANGE/NAVY **V1003-ON**
 MEN'S ORANGE/NAVY **V1002-ON**

FEATURES UPF 50+ / Breathable / Quick Dry / Day / Fluoro



CHIEF MICROFIBRE POLO SHIRT S/S V1000

- Genuine soft-touch microfibre
- Shoulder print design
- Breathable and quick dry fabric
- Unique panel design with contrast piping
- Complies with AS/NZS4399
- Complies with AS/NZS4602.1 - Class D
- Complies with AS/NZS1906.4 - Class F

FABRIC 175 gram Microfibre
SIZES S-6XL

CODES YELLOW/NAVY **V1000-YN**
 ORANGE/NAVY **V1000-ON**

FEATURES UPF 50+ / Breathable / Quick Dry / Day / Fluoro



CHIEF MICROFIBRE POLO SHIRT L/S

YELLOW/NAVY V2000-YN

UPF 50+ / Breathable / Quick Dry / Day / Fluoro



CHIEF MICROFIBRE POLO SHIRT L/S V2000

- Genuine soft-touch microfibre
- Shoulder print design
- Breathable and quick dry fabric
- Unique panel design with contrast piping
- Complies with AS/NZS4399
- Complies with AS/NZS4602.1 - Class D
- Complies with AS/NZS1906.4 - Class F

FABRIC 175 gram Microfibre
SIZES S-6XL

CODES YELLOW/NAVY **V2000-YN**
 ORANGE/NAVY **V2000-ON**

FEATURES UPF 50+ / Breathable / Quick Dry / Day / Fluoro



NAVY/BOTTLE PANEL ON FRONT ONLY



**DAY/NIGHT MICROFIBRE
POLO SHIRT S/S VPMRS**

- Genuine soft-touch microfibre
- Natural moisture removal characteristics
- Breathable and quick-dry
- Button down left breast pocket with pen partition
- 50mm 3M reflective tape
- Wash n wear characteristics
- Complies with AS/NZS4399
- Complies with AS/NZS4602.1 - Class D/N
- Complies with AS/NZS1906.4 - Class R/F

FABRIC 175 gram Microfibre
SIZES S-6XL

CODES YELLOW/NAVY **VPMRS-YN**
ORANGE/NAVY **VPMRS-ON**

FEATURES UPF 50+ / Breathable / Quick Dry / Day & Night /
Reflective & Fluoro / 3M Tape



**ORIGINAL MICROFIBRE
POLO SHIRT L/S VPML**

- Genuine soft-touch microfibre
- Contrasting front work panel
- Natural moisture removal characteristics
- Breathable and quick-dry
- Button down left breast pocket with pen partition
- Wash n wear characteristics
- Complies with AS/NZS4399
- Complies with AS/NZS4602.1 - Class D
- Complies with AS/NZS1906.4 - Class F

FABRIC 175 gram Microfibre
SIZES S-6XL

CODES YELLOW/NAVY **VPML-YN**
ORANGE/NAVY **VPML-ON**
YELLOW/BOTTLE **VPML-YB (AUS Only)**

FEATURES UPF 50+ / Breathable / Quick Dry / Day / Fluoro

**ORIGINAL MICROFIBRE
POLO SHIRT S/S VPMS**

- Genuine soft-touch microfibre
- Contrasting front work panel
- Natural moisture removal characteristics
- Breathable and quick-dry
- Button down left breast pocket with pen partition
- Wash n wear characteristics
- Complies with AS/NZS4399
- Complies with AS/NZS4602.1 - Class D
- Complies with AS/NZS1906.4 - Class F

FABRIC 175 gram Microfibre
SIZES S-6XL

CODES YELLOW/NAVY **VPMS-YN**
ORANGE/NAVY **VPMS-ON**
YELLOW/BOTTLE **VPMS-YB (AUS Only)**

FEATURES UPF 50+ / Breathable / Quick Dry / Day / Fluoro



**DAY/NIGHT MICROFIBRE
POLO SHIRT L/S V2002**

- Genuine soft-touch microfibre
- Natural moisture removal characteristics
- Breathable and quick-dry
- Button down left breast pocket with pen partition
- 50mm 3M reflective tape
- Wash n wear characteristics
- Complies with AS/NZS4399
- Complies with AS/NZS4602.1 - Class D/N
- Complies with AS/NZS1906.4 - Class R/F

FABRIC 175 gram Microfibre
SIZES S-6XL

CODES YELLOW/NAVY **V2002-YN (Aus Only)**
ORANGE/NAVY **V2002-ON (Aus Only)**

FEATURES UPF 50+ / Breathable / Quick Dry / Day & Night /
Reflective & Fluoro / 3M Tape





AERO MICROFIBRE POLO SHIRT S/S AVPMS

- Genuine soft-touch microfibre
- Panelled shoulder and sleeve design with contrast piping
- Natural moisture removal characteristics
- Breathable and quick-dry
- Button down left breast pocket with pen partition
- Wash n wear characteristics
- Complies with AS/NZS4399
- Complies with AS/NZS4602.1 - Class D
- Complies with AS/NZS1906.4 - Class F

FABRIC 175 gram Microfibre

SIZES S-6XL

CODES YELLOW/NAVY/RED TRIM **AVPMS-YN**
 ORANGE/NAVY/WHITE TRIM **AVPMS-ON**
 YELLOW/NAVY/SKY BLUE TRIM **AVPMS-YNS**

FEATURES UPF 50+ / Breathable / Quick Dry / Day / Fluoro



AERO MICROFIBRE POLO SHIRT S/S
YELLOW/NAVY/RED AVPMS-YN
 UPF 50+ / Breathable / Quick Dry / Day / Fluoro

ALL SAFE OPTIONS



AERO MICROFIBRE POLO SHIRT S/S
YELLOW/NAVY/SKY AVPMS-YNS
 UPF 50+ / Breathable / Quick Dry / Day / Fluoro



AERO MICROFIBRE POLO SHIRT S/S
ORANGE/NAVY/WHITE AVPMS-ON
 UPF 50+ / Breathable / Quick Dry / Day / Fluoro



AERO MICROFIBRE POLO SHIRT L/S
ORANGE/NAVY AVPML-ON & YELLOW/NAVY AVPML-YN
 UPF 50+ / Breathable / Quick Dry / Day / Fluoro



AERO MICROFIBRE POLO SHIRT L/S AVPML

- Genuine soft-touch microfibre
- Panelled shoulder and sleeve design with contrast piping
- Natural moisture removal characteristics
- Breathable and quick-dry
- Button down left breast pocket with pen partition
- Wash n wear characteristics
- Complies with AS/NZS4399
- Complies with AS/NZS4602.1 - Class D
- Complies with AS/NZS1906.4 - Class F

FABRIC 175 gram Microfibre
SIZES S-6XL

CODES YELLOW/NAVY/RED TRIM **AVPML-YN** (Aus Only)
 ORANGE/NAVY/WHITE TRIM **AVPML-ON** (Aus Only)

FEATURES UPF 50+ / Breathable / Quick Dry / Day / Fluoro



COTTON BACKED MICROFIBRE PREMIUM POLO SHIRT S/S VPCS

- Genuine microfibre front face with super soft combed cotton back face
- Provides an alternative to microfibre
- Natural feel/character of cotton against the skin
- Button down left breast pocket with pen partition
- Wash n wear characteristics
- Complies with AS/NZS4399
- Complies with AS/NZS4602.1 - Class D
- Complies with AS/NZS1906.4 - Class F

FABRIC 175 gram Microfibre
SIZES S-6XL

CODES YELLOW/NAVY **VPCS-YN**
 ORANGE/NAVY **VPCS-ON**
 YELLOW/BOTTLE **VPCS-YB** (AUS Only, While Stocks Last)

FEATURES UPF 50+ / Breathable / Quick Dry / Day / Fluoro



COTTON BACKED MICROFIBRE PREMIUM POLO SHIRT L/S
ORANGE/NAVY VPCL-ON
 UPF 50+ / Breathable / Quick Dry / Day / Fluoro



NAVY PANEL ON FRONT ONLY

COTTON BACKED MICROFIBRE PREMIUM POLO SHIRT L/S VPCL

- Genuine microfibre front face with super soft combed cotton back face
- Provides an alternative to microfibre
- Natural feel/character of cotton against the skin
- Button down left breast pocket with pen partition
- Wash n wear characteristics
- Complies with AS/NZS4399
- Complies with AS/NZS4602.1 - Class D
- Complies with AS/NZS1906.4 - Class F

FABRIC 175 gram Microfibre
SIZES S-6XL

CODES YELLOW/NAVY **VPCL-YN**
 ORANGE/NAVY **VPCL-ON**
 YELLOW/BOTTLE **VPCL-YB** (AUS Only, While Stocks Last)

FEATURES UPF 50+ / Breathable / Quick Dry / Day / Fluoro





COMMANDO MICROFIBRE POLO SHIRTS V1001/V2001

- Genuine soft-touch microfibre
- Unique panel design with contrast piping
- Complies with AS/NZS4602.1 - Class D
- Complies with AS/NZS4399
- Complies with AS/NZS1906.4 - Class F

SHORT SLEEVE

FABRIC 175 gram Microfibre

SIZES S-6XL

CODES YELLOW/NAVY **V1001-YN**
ORANGE/NAVY **V1001-ON**

FEATURES UPF 50+ / Breathable / Quick Dry / Day / Fluoro

LONG SLEEVE

FABRIC 175 gram Microfibre

SIZES S-6XL

CODES YELLOW/NAVY **V2001-YN**
ORANGE/NAVY **V2001-ON**

FEATURES UPF 50+ / Breathable / Quick Dry / Day / Fluoro



COMMANDO MICROFIBRE POLO SHIRT L/S

YELLOW/NAVY V2001-YN

UPF 50+ / Breathable / Quick Dry / Day / Fluoro



YOUR
LOGO HERE

WINTER



THE WINTER RANGE

*5 AM START? STAY WARM AND SAFE
WITH VISITEC THIS WINTER.*

The heavy weight fleece and polar fleece are tough, durable and built for work. Complying with Australian and New Zealand standards, each garment can withstand wear and washing without pilling or fading.

VISITEC winter garments boast an array of features, including reflective zips and piping trims, spliced work fronts, kanga pockets and chunky rib cuffs, ensuring superior function and warmth through the colder months.

NEW



SHIELD THE ELEMENTS

ARMOUR DAY/NIGHT SWEATSHIRT V6002

- Durable heavyweight fleece fabric
- Contrasting front spliced work panel
- Genuine 3M reflective tape
- Zipper with reflective detail
- High neckline for greater wind protection
- Side front "Kanga" pockets
- Complies with AS/NZS4399
- Complies with AS/NZS4602.1 - Class D/N
- Complies with AS/NZS1906.4 - Class R/F

FABRIC 320 gram Polyester

SIZES S-6XL

CODES YELLOW/NAVY V6002-YN

ORANGE/NAVY V6002-ON

FEATURES UPF 50+ / Day & Night / Reflective & Fluoro / 3M Tape



ARMOUR DAY/NIGHT SWEATSHIRT
 YELLOW/NAVY V6002-YN
 UPF 50+ / Day & Night / Reflective & Fluoro / 3M Tape



HALF ZIP SWEATSHIRT (DAY USE) V6000

- Durable heavyweight fleece fabric
- Contrasting front spliced work panel and shoulder yoke
- High neckline for greater wind protection
- Unique reflective piping
- Side front "Kanga" pockets
- Complies with AS/NZS4399
- Complies with AS/NZS1906.4 - Class F
- Zipper with reflective detail
- Internal MP3/Phone pocket
- Complies with AS/NZS4602.1 - Class D

FABRIC 320 gram Polyester

SIZES S-6XL

CODES YELLOW/NAVY **V6000-YN**
ORANGE/NAVY **V6000-ON**

FEATURES UPF 50+ / Day / Fluoro



HALF ZIP SWEATSHIRT (DAY USE)
YELLOW/NAVY V6000-YN
UPF 50+ / Day / Fluoro



ZIPPER WITH
REFLECTIVE DETAIL

NAVY PANEL ON FRONT AND BACK



REFLECTIVE
PIPING TRIM

HOODIE
ORANGE/NAVY V600I-ON
UPF 50+



HOODIE V600I

- Durable heavyweight fleece fabric
- Contrasting front spliced work panel and shoulder yoke
- Reflective piping trim
- Zipper with reflective detail
- Lined hood for protection from the elements
- Side front "Kanga" pockets
- Internal MP3/Phone pocket
- Complies with AS/NZS4399
- Complies with AS/NZS4602.1 - Class D
- Complies with AS/NZS1906.4 - Class F

FABRIC 320 gram Polyester
SIZES S-6XL

CODES YELLOW/NAVY V600I-YN
ORANGE/NAVY V600I-ON

FEATURES UPF 50+ / Day / Fluoro

CODES NAVY V600I-N
BLACK V600I-BK

FEATURES UPF 50+





ORIGINAL POLAR FLEECE JUMPER

YELLOW/BOTTLE VPF-YB

UPF 50+ / Day / Fluoro



ORIGINAL POLAR FLEECE JUMPER VPF

- Durable heavyweight anti-pill polar fleece
- Contrasting front work panel
- High neckline for greater wind protection
- Chunky zip half front
- Side pockets
- Internal elastic draw cord with toggles
- Complies with AS/NZS4399
- Complies with AS/NZS4602.1 - Class D
- Complies with AS/NZS1906.4 - Class F

FABRIC 320 gram Polyester

SIZES S-6XL

CODES YELLOW/NAVY **VPF-YN**
 ORANGE/NAVY **VPF-ON**
 YELLOW/BOTTLE **VPF-YB**

FEATURES UPF 50+ / Day / Fluoro



DAY/NIGHT BASIC POLAR FLEECE JUMPER

ORANGE/NAVY VPFR-ON

UPF 50+ / Day & Night / Reflective & Fluoro / 3M Tape



DAY/NIGHT BASIC POLAR FLEECE JUMPER VPFR

- Durable heavyweight anti-pill fabric
- Contrasting front spliced work panel
- Genuine 50mm, 3M reflective tape
- High neckline for greater wind protection
- Side front pockets
- Internal elastic draw cord with toggles
- Complies with AS/NZS4399
- Complies with AS/NZS4602.1 - Class D/N
- Complies with AS/NZS1906.4 - Class R/F

FABRIC 320 gram Polyester

SIZES S-6XL

CODES YELLOW/NAVY **VPFR-YN**
 ORANGE/NAVY **VPFR-ON**

FEATURES UPF 50+ / Day / Fluoro





◀ **HEAVYWEIGHT SLOPPY JOE SWEATSHIRT VSJ**

- Enhanced polyester front face for increased visibility
- Durable heavyweight low-pill fabric
- Navy contrast front work panel
- Rib cuffs and Basque
- Complies with AS/NZS4399
- Complies with AS/NZS4602.1 - Class D
- Complies with AS/NZS1906.4 - Class F

FABRIC 320 gram Polyester
SIZES S-6XL

CODES YELLOW/NAVY **VSJ-YN**
 ORANGE/NAVY **VSJ-ON**

FEATURES UPF 50+ / Day / Fluoro



CLASSIC COMFORT



HEAVYWEIGHT SLOPPY JOE SWEATSHIRT
 YELLOW/NAVY VSJ-YN & ORANGE/NAVY VSJ-ON
 UPF 50+ / Day / Fluoro



NAVY PANEL ON FRONT AND BACK

▶ **THE FLANNY COTTON WORKSHIRT L/S WWFL**

- Extra warmth and comfort
- Button through front style
- Double chest button patch pockets
- Pen partition on left pocket
- Navy contrasting front split, back split and half sleeve
- Complies with AS/NZS4399
- Complies with AS/NZS4602.1 - Class D (Y/N, O/N)
- Complies with AS/NZS1906.4 - Class F (Y/N, O/N)

FABRIC 170 gram Cotton Flannelette
SIZES S-6XL

CODES YELLOW/NAVY **WWFL-YN**
 ORANGE/NAVY **WWFL-ON**

FEATURES UPF 50+ / Day / Fluoro

CODE NAVY **WWFL-N** (Aus Only)

FEATURE UPF 50+



THE FLANNY COTTON WORKSHIRT L/S
 NAVY WWFL-N
 UPF 50+

3M TAPE CONFIGURATION
SAME ON FRONT AND BACK



► PLAIN WOOL BLUEY JACKET **WBJ**

- Midweight
- Fine grade micron wool for softness & comfort
- Chunky zip closure
- Left breast flap pocket
- Complies with AS/NZS4399
- Complies with AS/NZS4602.1 - Class D (Y/C,D/C)
- Complies with AS/NZS1906.4 - Class F (Y/C,D/C)

FABRIC 90% Wool / 10% Viscose
SIZES S-6XL

CODES YELLOW/CHARCOAL **WBJ-YC** (Aus Only)
 ORANGE/CHARCOAL **WBJ-OC** (Aus Only)

FEATURES UPF 50+ / Breathable / Day & Night /
 Reflective & Fluoro / 3M Tape

CODE CHARCOAL **WBJ-C**
FEATURES UPF 50+ / Breathable



► DAY/NIGHT HI-VIS WOOL BLUEY JACKET **WBJR**

- High Visibility panels front and back
- Fine grade micron wool for softness & comfort
- Chunky zip closure
- Left breast flap pocket
- Genuine 50mm, 3M reflective tape applied in the harness style
- Complies with AS/NZS4399
- Complies with AS/NZS4602.1 - Class D/N
- Complies with AS/NZS1906.4 - Class R/F

FABRIC 90% Wool / 10% Viscose
SIZES S-6XL

CODES YELLOW/CHARCOAL **WBJR-YC** (Aus Only)
 ORANGE/CHARCOAL **WBJR-OC**

FEATURES UPF 50+ / Breathable / Day & Night /
 Reflective & Fluoro / 3M Tape



DAY/NIGHT HI VIS WOOL BLUEY JACKET
ORANGE/CHARCOAL WBJR-OC
 UPF 50+ / Breathable / Day & Night / Reflective & Fluoro / 3M Tape

WET WEATHER



THE WET WEATHER RANGE

*KEEPING YOU DRY IS ONLY HALF THE JOB
OF A QUALITY RAIN JACKET.*

The VISITEC Elements range is breathable and waterproof. The fabric has been tested and developed to provide excellence in 2 specific areas:

1. Hydrostatic pressure testing. This test measures water resistance to ensure the jacket is waterproof from external elements.
2. Moisture vapour permeability (MVP). This tests the release of excess moisture and heat from within the jacket fabric.

VISITEC garments include waterproof zippers, ID pockets, hand warmer pockets, "pit zips" to enhance underarm airflow, dedicated MP3 or phone pockets, and various concealed vents which prevent water entry while still allowing airflow.

The VISITEC wet weather jacket provides protection with the added comfort of breathability.

1. INNER VEST

2. INNER VEST JACKET WITH SLEEVES

3. OUTER JACKET / 4. OUTER JACKET + INNER VEST / 5. OUTER JACKET + INNER VEST JACKET WITH SLEEVES



ELEMENTS "5-IN-1" JACKET V7000

- Day/Night Outer shell jacket
- Day/Night Inner Jacket with zip off quilted sleeves
- Day/Night Inner jacket converts to Day/Night vest by zipping off sleeves
- All items 100% waterproof and seam sealed
- Dual entry MP3/ Phone pocket
- Waterproof zipper pockets
- Hand warmer pockets
- Silicone ID pocket and cuff adjusters
- Genuine 50mm, 3M reflective tape
- Vest also zips into V7001 Breathable Racing jacket
- Complies with AS/NZS4399
- Complies with AS/NZS4602.1 - Class D/N
- Complies with AS/NZS1906.4 - Class R/F

FABRIC 300 Denier Oxford Polyester

SIZES S-6XL

CODES YELLOW/NAVY **V7000-YN**

ORANGE/NAVY **V7000-ON**

FEATURES UPF 50+ / Breathable / Waterproof / Zip In Sleeves / Day & Night / Reflective & Fluoro / 3M Tape



1. INNER VEST

Wear the day / night vest without the zip off sleeves when you need the lightest, HiVis protection.

2. INNER VEST JACKET WITH SLEEVES

Zip the sleeves onto the vest when the temperature drops for a lightweight alternative to the full jacket.

3. OUTER JACKET

Wear the Elements jacket on its own and use all the benefits of the innovative design and features.

4. OUTER JACKET + INNER VEST

For medium weight protection against the elements, zip the vest into the jacket and cut out the cold.

5. OUTER JACKET + INNER VEST JACKET WITH SLEEVES

For the ultimate in protection and warmth, zip the vest and sleeves into the 5 in 1 jacket and get to work in comfort.



MP3 OR
PHONE POCKET

SILICONE
ID POCKET

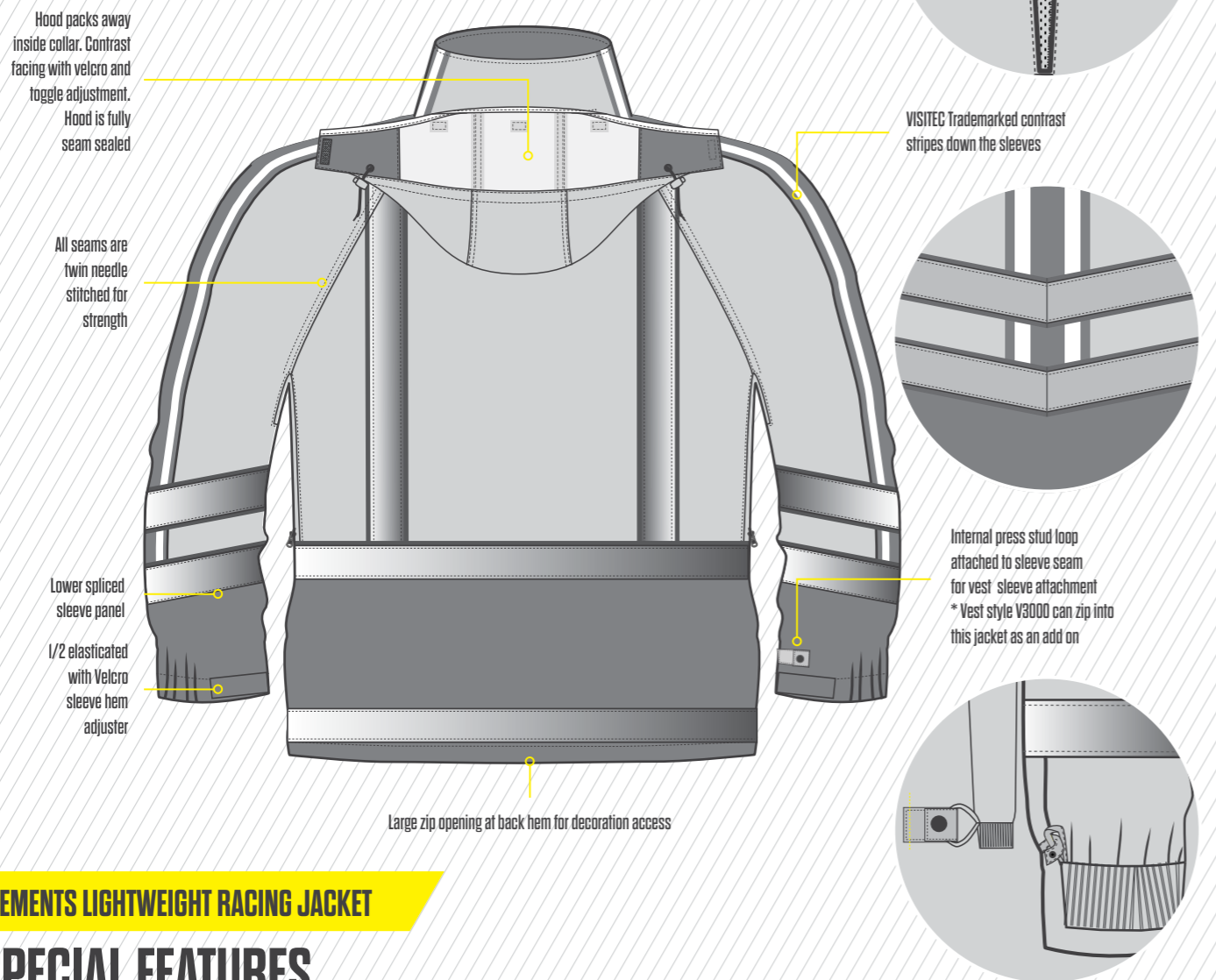
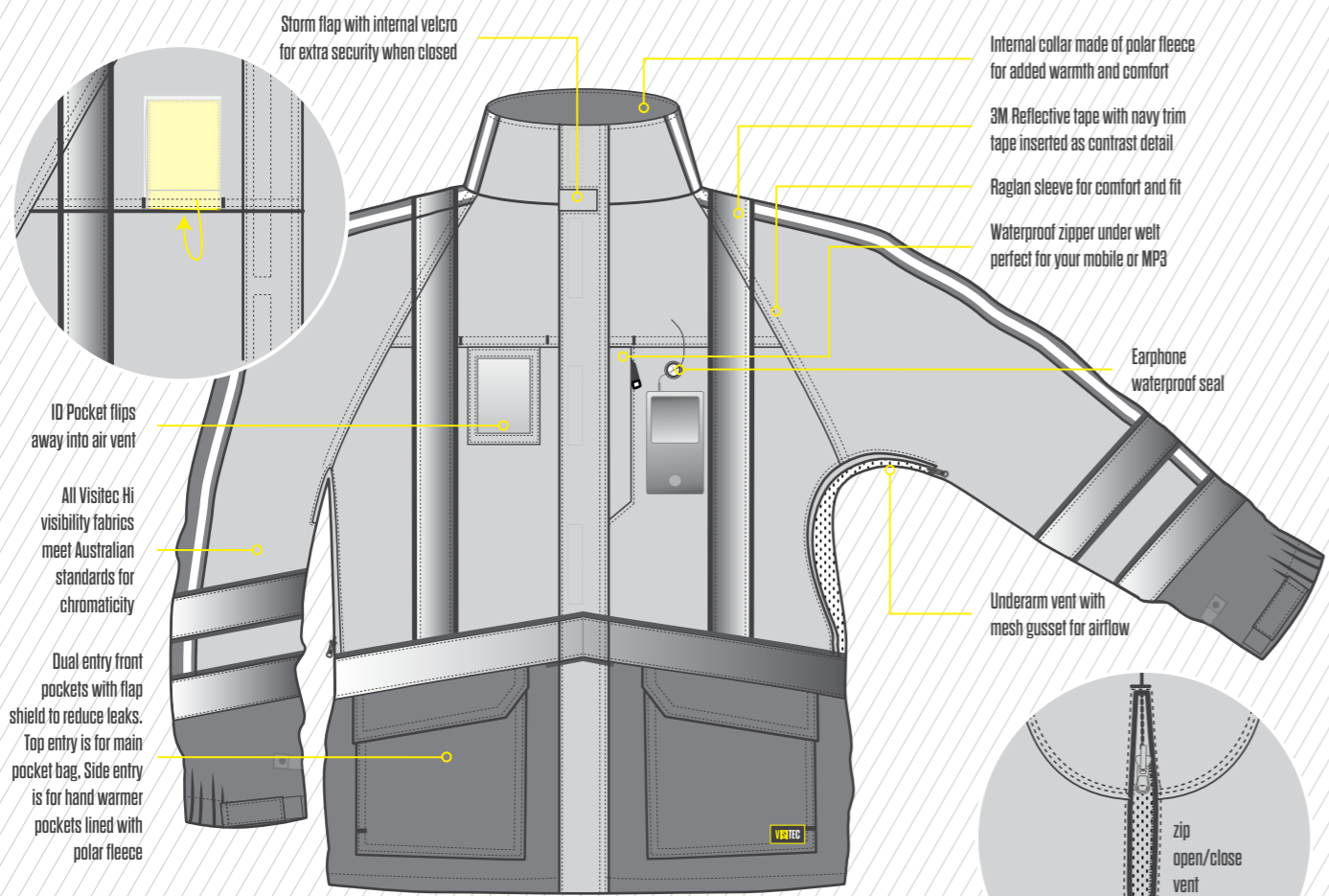

ELEMENTS LIGHTWEIGHT RACING JACKET* V7001

- Jacket is fully breathable polyester/PU with mesh lining
- 100% waterproof and seam sealed
- Racing inspired sleeve and stripe detail
- ID flip pocket and MP3/Phone pocket
- Genuine 50mm, 3M reflective tape
- V3000 vest can zip into this jacket for extra warmth
- Complies with AS/NZS4399
- Complies with AS/NZS4602.1 - Class D/N
- Complies with AS/NZS1906.4 - Class R/F
- Waterproof zipper pocket
- Hand warmer pockets

FABRIC 300 Denier Oxford Polyester

SIZES S-6XL

CODES YELLOW/NAVY **V7001-YN**

ORANGE/NAVY **V7001-ON**

FEATURES UPF 50+ / Breathable / Waterproof / Zip In Sleeves / Day & Night / Reflective & Fluoro / 3M Tape



*The VISITEC Racing Stripes are a registered trademark.





◀ ELEMENTS VEST V3000

- Quilt lined
- Built to zip into V7000 and V7001 jackets for added warmth
- 100% waterproof and seam sealed
- Hand warmer and phone pockets
- Genuine 50mm, 3M reflective tape
- Complies with AS/NZS4399
- Complies with AS/NZS4602.1 - Class D/N
- Complies with AS/NZS1906.4 - Class R/F

FABRIC 300 Denier Oxford Polyester
SIZES S-6XL

CODES YELLOW **V3000-Y** (Aus Only)
 ORANGE **V3000-O** (Aus Only)

FEATURES UPF 50+ / Breathable / Waterproof / Zip In Sleeves /
 Day & Night / Reflective & Fluoro / 3M Tape



ELEMENTS VEST

YELLOW V3000-Y

UPF 50+ / Breathable / Waterproof / Zip In Sleeves /
 Day & Night / Reflective & Fluoro / 3M Tape



◀ STORMSTOPPER JACKET VJS

- 100% waterproof (fully seam sealed)
- High neckline and longer length for warmth and weather protection
- Concealed foldaway hood in back neck
- Fully concealed storm flap
- Internal storm cuffs and adjustable tabs
- Mobile phone pocket with flap and pen holder at left breast
- Internal elasticized draw cord
- Genuine 50mm, 3M reflective tape
- Complies with AS/NZS4399
- Complies with AS/NZS4602.1 - Class D/N
- Complies with AS/NZS1906.4 - Class R/F

FABRIC 300D Oxford Polyester
SIZES S-6XL

CODES YELLOW/NAVY **VJS-YN**
 ORANGE/NAVY **VJS-ON**
 ORANGE **VJS-O** (NZ Only)

FEATURES UPF 50+ / Waterproof / Day & Night / Reflective & Fluoro / 3M Tape



◀ STORMSTOPPER PANT VSP

- 100% waterproof (fully seam sealed)
- Hideaway side pockets
- Zip up legs to go over work boots
- Elastic and draw cord waist
- Internal storm cuffs and adjustable tabs
- Genuine 50mm, 3M reflective tape
- Complies with AS/NZS4399
- Complies with AS/NZS4602.1 - Class D/N
- Complies with AS/NZS1906.4 - Class R/F

FABRIC 300D Oxford Polyester
SIZES S-6XL

CODES YELLOW **VSP-Y**
 ORANGE **VSP-O**

FEATURES UPF 50+ / Waterproof / Day & Night / Reflective & Fluoro / 3M Tape



▶ BRANDING SPACE FOR YOUR LOGO





DAY/NIGHT FLYING JACKET

ORANGE/NAVY VJFR-ON

UPF 50+ / Waterproof / Day & Night / Reflective & Fluoro / 3M Tape



DAY/NIGHT FLYING JACKET VJFR

- 100% waterproof (fully seam sealed)
- Spliced sleeves reduce soiling
- Concealed foldaway hood in back neck
- Knitted neck, cuffs and basque
- Internal pocket and sleeve pocket
- Genuine 50mm, 3M reflective tape applied in harness style
- Complies with AS/NZS4399
- Complies with AS/NZS4602.1 - Class D/N
- Complies with AS/NZS1906.4 - Class R/F

FABRIC 300D Oxford Polyester

SIZES S-5XL

CODES YELLOW/NAVY **VJFR-YN**

ORANGE/NAVY **VJFR-ON**

FEATURES UPF 50+ / Waterproof / Day & Night / Reflective & Fluoro / 3M Tape



FLYING JACKET

YELLOW/NAVY VJF-YN

UPF 50+ / Waterproof / Day / Fluoro

FLYING JACKET VJF

- 100% waterproof (fully seam sealed)
- Spliced sleeves reduce soiling
- Concealed foldaway hood in back neck
- Knitted neck, cuffs and Basque
- Internal pocket and sleeve pocket
- Complies with AS/NZS4399
- Complies with AS/NZS4602.1 - Class D
- Complies with AS/NZS1906.4 - Class R

FABRIC 300D Oxford Polyester

SIZES S-5XL

CODES YELLOW/NAVY **VJF-YN**

ORANGE/NAVY **VJF-ON**

YELLOW/BOTTLE **VJF-YB**

FEATURES UPF 50+ / Waterproof / Day / Fluoro



3M TAPE CONFIGURATION
SAME ON FRONT AND BACK



SOFT FLEX RAINWEAR SET

FLUORO ORANGE VHVR-0

UPF 50+ / Waterproof / Day & Night / Reflective & Fluoro / 3M Tape



SOFT FLEX RAINWEAR SET VHVR

- 100% waterproof (fully seam sealed) fabric with superior
- 'Stretch' to stop seam splitting
- Super lightweight bonded PU Polyester with knitted backing, much lighter than traditional PVC rainwear
- Plastic press stud closures • Fully concealed front placket
- Internal storm cuffs • Stowaway hood
- Genuine 50mm, 3M reflective tape
- Complies with AS/NZS4399
- Complies with AS/NZS4602.1 - Class D/N
- Complies with AS/NZS1906.4 - Class R/F

FABRIC 300 Denier Oxford Polyester

SIZES S-6XL

CODES FLUORO YELLOW **VHVR-Y** (Aus Only)

FLUORO ORANGE **VHVR-O** (Aus Only)

FEATURES UPF 50+ / Waterproof / Day & Night / Reflective & Fluoro / 3M Tape



NEW ZEALAND



THE NEW ZEALAND ONLY RANGE

Designed for **Temporary Traffic Management Control (TTMC)** in compliance with the NZ Transport Agency code of practice. As standards change, VISITEC changes too.

All VISITEC TTMC garments are compliant to the relevant New Zealand Standards and are updated to comply to the (draft) fourth edition copTTMC.

3M TAPE CONFIGURATION SAME ON FRONT AND BACK



ALL GARMENTS TTMC-W COMPLIANT

▶ TTMC FLEECE LINED VEST VRV

- Durable heavyweight oxford polyester shell with anti-pill micro-polar fleece lining
- Full length zip up to high neckline
- Cell phone pocket, internal pocket, front flap pockets and side pockets
- Longer tail at back with reflective tape
- Genuine 50mm 3M reflective tape applied to
- TTMC specifications
- Complies with AS/NZS4399, 4602.1, 1906.4

FABRIC 3000 Oxford Polyester (Outer) / 260 gram Anti Pill Polar Fleece (Inner)
SIZES S-6XL

CODES YELLOW **VRV-Y** (Not TTMC-W Compliant)
ORANGE **VRV-O**

FEATURES UPF 50+ / Quick Dry / Waterproof / Day & Night / Reflective & Fluoro / 3M Tape

▶ TTMC VEST TTMC

- Durable polyester with zip front closure
- Cell phone pocket, internal pocket, pen pocket
- Longer tail at back with reflective tape
- Genuine 50mm 3M reflective tape applied to
- TTMC specifications
- Complies with AS/NZS4602.1 - Class D/N
- Complies with AS/NZS1906.4 - Class R/F

FABRIC Polyester
SIZES S-6XL

CODE ORANGE ONLY **TTMC-O**

FEATURES Day & Night / Reflective & Fluoro / 3M Tape

TTMC DAY/NIGHT MICROFIBRE POLO SHIRT S/S

ORANGE TTVPMS-O

UPF 50+ / Breathable / Quick Dry / Day & Night / Reflective & Fluoro / 3M Tape



TTMC DAY/NIGHT MICROFIBRE POLO SHIRT S/S TTVPMS

- Genuine soft-touch microfibre
- Breathable and quick-dry
- Extra tail length with 3M reflective tape
- Button down left breast pocket with pen partition
- Genuine 50mm 3M reflective tape applied to
- TTMC specifications
- Complies with AS/NZS4399
- Complies with AS/NZS4602.1 - Class D/N
- Complies with AS/NZS1906.4 - Class R/F
- Complies with wet weather performance test TTMC-W

FABRIC 175 gram Microfibre

SIZES S-6XL + 8XL

CODE ORANGE ONLY **TTVPMS-O**

FEATURES UPF 50+ / Breathable / Quick Dry / Day & Night / Reflective & Fluoro / 3M Tape



3M TAPE CONFIGURATION SAME ON FRONT AND BACK



TTMC VEST
ORANGE TTMC-O

Day & Night / Reflective & Fluoro / 3M Tape

METRIC SIZE	77R	82R	87R	92R	97R	102R	107R	92S	97S	102S	107S	112S	117S	122S
WAIST (inches)	30	32	34	36	38	40	42	36	38	40	42	44	46	48
CHEST (cm)	87	92	97	102	107	112	117	97	102	107	112	117	122	127
WAIST (cm)	77	82	87	92	97	102	107	92	97	102	107	112	117	122
INSIDE LEG (cm)	83	83	84	84	86	86	86	73	75	78	79	80	81	82

METRIC SIZE	72R	77R	82R	87R	92R	97R	102R	107R	92S	97S	102S	107S	112S	117S	122S
WAIST (inches)	28	30	32	34	36	38	40	42	36	38	40	42	44	46	48
WAIST (cm)	72	77	82	87	92	97	102	107	92	97	102	107	112	117	122
INSIDE LEG (cm)	83	83	83	84	84	86	86	86	73	75	78	79	80	81	82

METRIC SIZE	72R	77	82	87	92	97	102	107	112	117
WAIST (inches)	28	30	32	34	36	38	40	42	44	46
WAIST (cm)	72	77	82	87	92	97	102	107	112	117

IMPERIAL SIZE	SML	MED	LGE	XL	2XL	3XL	4XL	5XL	6XL
METRIC SIZE (Neck cm)	38	40	42	44	46	48	50	52	54
TO FIT CHEST (cm)	95	100	105	110	115	120	125	130	135

IMPERIAL SIZE	SML	MED	LGE	XL	2XL	3XL	4XL	5XL	6XL
STANDARD SIZE	16	18	20	22	24	26	28	30	32
METRIC SIZE (Neck cm)	38	40	42	44	46	48	50	52	54
TO FIT CHEST (cm)	95	100	105	110	115	120	125	130	135

IMPERIAL SIZE	SML	MED	LGE	XL	2XL	3XL	4XL	5XL	6XL
STANDARD SIZE	16	18	20	22	24	26	28	30	32
METRIC SIZE (Neck cm)	38	40	42	44	46	48	50	52	54
TO FIT CHEST (cm)	95	100	105	110	115	120	125	130	135

IMPERIAL SIZE	SML	MED	LGE	XL	2XL	3XL	4XL	5XL	6XL
STANDARD SIZE	16	18	20	22	24	26	28	30	32
METRIC SIZE (Neck cm)	38	40	42	44	46	48	50	52	54
TO FIT CHEST (cm)	95	100	105	110	115	120	125	130	135

IMPERIAL SIZE	SML	MED	LGE	XL	2XL	3XL	4XL	5XL
STANDARD SIZE	16	18	20	22	24	26	28	30
METRIC SIZE (Neck cm)	36	38	40	42	44	46	48	50
TO FIT CHEST (cm)	90	95	100	105	110	115	120	125

WOMEN'S POLO & WORKSHIRTS

IMPERIAL SIZE	XS	S	M	L	XL	2XL	3XL	4XL
STANDARD SIZE	8	10	12	14	16	18	20	22
BUST (cm)	82	87	92	97	102	107	112	117

WOMEN'S PANTS

SIZE	8	10	12	14	16	18	20	22
WAIST (inches)	26	28	30	32	33	35	37	39
WAIST (cm)	68	72	77	82	87	92	97	102
HIP (cm)	91	96	101	106	111	116	122	128

HOW TO MEASURE YOURSELF (MALE)

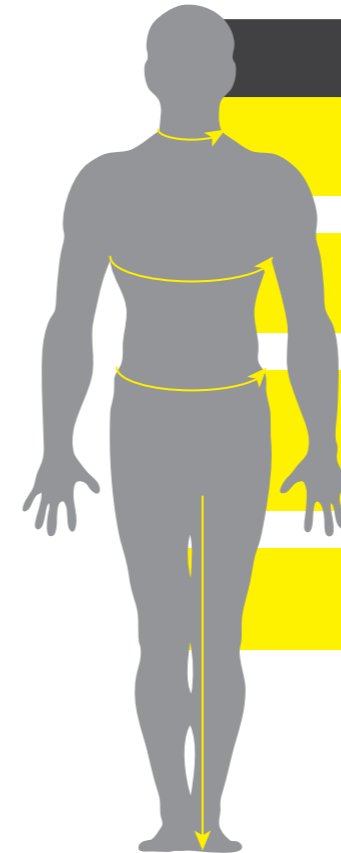

NECK: Measure around your neck where the collar sits, allowing two fingers behind the tape measure for comfort.

CHEST: Measure around the fullest part of your chest at the under arm point, ensuring tape measure is level across the back.

WAIST: Measure with a tape measure around your natural waist line, this is where your pants sit. Do not measure over the waistband of the pants you are wearing! You should measure for a firm yet comfortable fit against the skin.

INSIDE LEG: Measure from the fork of the seams under your crotch down to the top of the heel of your shoe, this should be about 1cm from the floor.

HOW TO MEASURE YOURSELF (FEMALE)

BUST: Measure around the body with the measuring tape on top of the fullest part of the bust. Keeping the tape measure level and straight, put 1 finger under the tape measure to give yourself a little extra room for comfort.

NATURAL WAIST: Measure around the smallest part of your waistline. Keeping the tape measure level and straight, put 1 finger under the tape measure to give yourself a little extra for comfort. Do not measure over the top of another pair of pants or jeans.

HIP: Measure around the widest part of your hips (sorry to do this) approximately 20 to 30cm below your natural waistline. This will be the widest part of your bottom, put 1 finger under the tape measure to give yourself a little extra for comfort. Do not measure over the top of another pair of pants or skirt.

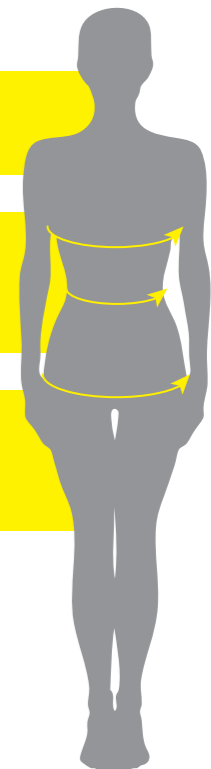

AIRWEAR RANGE	37	NEW ZEALAND ONLY RANGE	93
BASIC AIRWEAR@ POLO SHIRT L/S	45	TTMC DAY/NIGHT MICROFIBRE POLO SHIRT S/S	95
BASIC AIRWEAR@ POLO SHIRT S/S	44	TTMC FLEECE LINED VEST	94
CHARGER AIRWEAR@ POLO SHIRT S/S	39	TTMC VEST	94
CLASSIC AIRWEAR@ POLO SHIRT S/S	44		
FIREWIRE AIRWEAR@ POLO SHIRT S/S	41	WINTER RANGE	67
MATRIX AIRWEAR@ POLO SHIRT S/S	38	ARMOUR DAY/NIGHT SWEATSHIRT	68
PRO AIRWEAR@ POLO SHIRT S/S	43	DAY/NIGHT BASIC POLAR FLEECE JUMPER	74
WARRIOR AIRWEAR@ POLO SHIRT S/S	40	DAY/NIGHT HI VIS WOOL BLUEY JACKET	79
		HALF ZIP SWEATSHIRT (DAY USE)	70
		HEAVYWEIGHT SLOPPY JOE SWEATSHIRT	76
		HOODIE	73
		ORIGINAL POLAR FLEECE JUMPER	75
		PLAIN WOOL BLUEY JACKET	79
		THE FLANNY COTTON WORKSHIRT L/S	77
FUSION RANGE	5	WORKWEAR RANGE	21
FUSION CARGO PANT	10	COTTON CARGO PANT	28
FUSION CARGO SHORT	9	COTTON CARGO SHORT	28
FUSION LIGHTWEIGHT D/N HI-VIS SHIRT L/S	17	COTTON DRILL COMBINATION OVERALLS	33
FUSION LIGHTWEIGHT SHIRT L/S	14	COTTON DRILL COMBINATION TAPED OVERALLS	33
FUSION LIGHTWEIGHT SHIRT S/S	13	COTTON DRILL UTILITY PANT	31
FUSION LIGHTWEIGHT UTILITY PANT	7	COTTON DRILL WORKSHIRT L/S	30
FUSION UTILITY PANT	7	COTTON DRILL WORKSHIRT S/S	29
WOMEN'S FUSION D/N HI-VIS SHIRT L/S	18	DAY/NIGHT HI-VIS COTTON DRILL WORKSHIRT L/S	32
WOMEN'S FUSION PANT	18	ELASTIC WAIST VEST (DAY/NIGHT USE)	35
VISITEC COOL SCARF	17	ELASTIC WAIST VEST (DAY USE)	35
		ENDURAMAX@ PANT	24
		ENDURAMAX@ SHORT	24
		ORIGINAL DRILL PANT WITH 3M REFLECTIVE TAPE	32
		TITAN DRILL PANT	23
		VELCRO 'BUDGET' VEST (DAY/NIGHT USE)	34
		VELCRO 'BUDGET' VEST (DAY USE)	34
		WORK BOARDIE	27
MICROFIBRE RANGE	47	WET WEATHER RANGE	81
AERO MICROFIBRE POLO SHIRT L/S	62	DAY/NIGHT FLYING JACKET	89
AERO MICROFIBRE POLO SHIRT S/S	61	ELEMENTS "5-IN-1" JACKET	83
CHIEF MICROFIBRE POLO SHIRT L/S	57	ELEMENTS LIGHTWEIGHT RACING JACKET	85
CHIEF MICROFIBRE POLO SHIRT S/S	57	ELEMENTS VEST	86
COMMANDO MICROFIBRE POLO SHIRTS	65	FLYING JACKET	88
COTTON BACKED MICROFIBRE PREMIUM POLO SHIRT L/S	63	SOFT FLEX RAINWEAR SET	91
COTTON BACKED MICROFIBRE PREMIUM POLO SHIRT S/S	63	STORMSTOPPER JACKET	87
DAY/NIGHT MICROFIBRE POLO SHIRT L/S	59	STORMSTOPPER PANT	87
DAY/NIGHT MICROFIBRE POLO SHIRT S/S	59		
ENERGY MICROFIBRE POLO S/S	56		
GEO MICROFIBRE POLO SHIRT S/S	50		
ORIGINAL MICROFIBRE POLO SHIRT L/S	58		
ORIGINAL MICROFIBRE POLO SHIRT S/S	58		
RACING STRIPE MICROFIBRE POLO SHIRT L/S	48		
RACING STRIPE MICROFIBRE POLO SHIRT S/S	48		
RACING STRIPE MICROFIBRE SINGLET	53		
TRIO MICROFIBRE SINGLET	54		
VORTEX MICROFIBRE POLO SHIRT S/S	55		

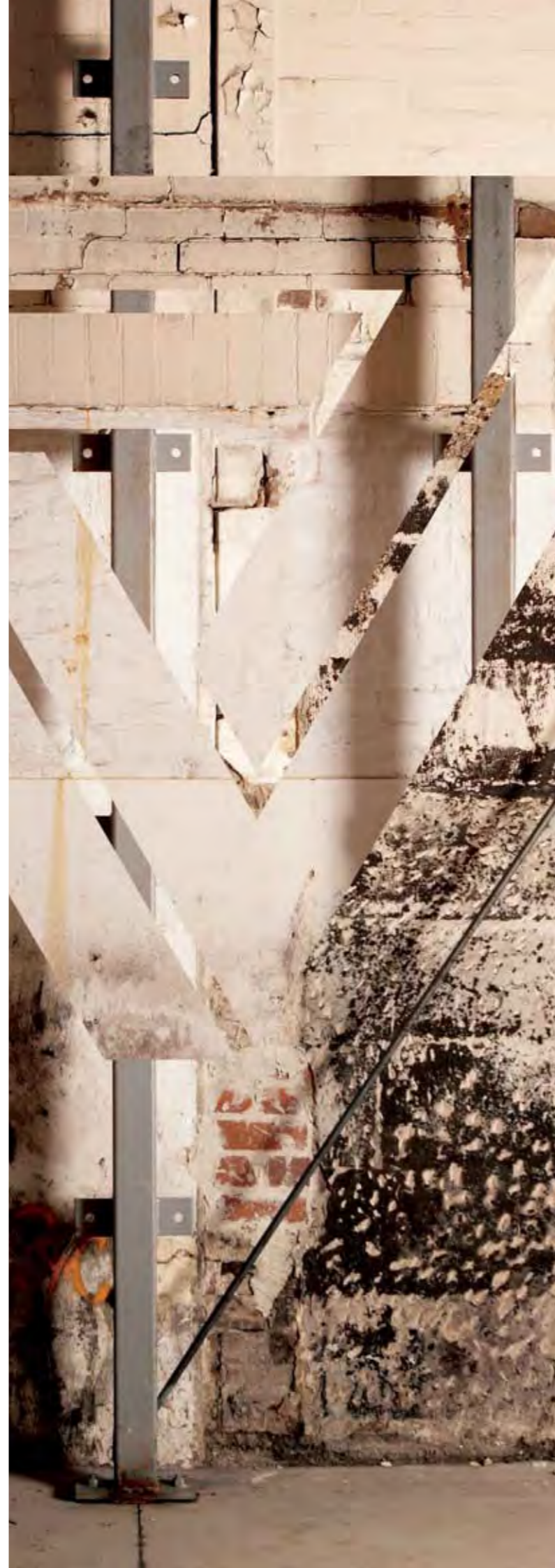

WE WOULD LIKE TO THANK OUR FRIENDS AT TRIVEST FOR THE GENEROUS USE OF THEIR LOCATION AT ALEXANDRIA CREATIVE PARK.

Disclaimer: VISITEC Australia Pty Ltd and VISITEC New Zealand Ltd has no control over the end use of any of the enclosed high visibility products. The performance criteria of all high visibility product enclosed within this catalogue is tested at time of manufacture in accordance with Australian and New Zealand standards, but can diminish with time, UV exposure, general soiling, misuse or failure to follow specified washing instructions contained within each garment. Customers should undertake their own tests by independent qualified personnel to determine the suitability of the product(s) for that customer/consumers use. VISITEC Australia Pty Ltd and VISITEC New Zealand Ltd does not warrant the performance characteristics of garments and fabrics and no more warranty of any type is given, intended or implied herein. Colours in this catalogue are representative only and not true to actual garments.

AUSTRALIA

PO BOX 6113 . Alexandria . NSW 2015 . Australia

PHONE +61 2 9557 6533

FAX +61 2 9516 5091

CUSTOMER SERVICE +61 2 9557 6533

EMAIL sales@visitec.com.au

VISITEC.COM.AU

NEW ZEALAND

34 Apollo Drive . Mairangi Bay . Auckland . New Zealand

PHONE +64 9 985 3500

FAX +64 9 479 7055

CUSTOMER SERVICE +64 9 985 3500

EMAIL sales@visitec.co.nz

VISITEC.CO.NZ

VISITEC 